

IOA **INSTITUTO OTAVALEÑO DE ANTROPOLOGIA**
CENTRO REGIONAL DE INVESTIGACIONES

Colección

PENDONEROS

Con renovada fe en el futuro, los Miembros de Número del IOA se complacen en entregar la presente publicación, como homenaje a su Patria, en el Sesquicentenario de vida republicana.

Alfonso Cabascango Rubio

Marcelo Valdospinos Rubio

Renán Cisneros del Hierro

Miguel A. Hermosa Cabezas

Carlos Benavides Vega

Bolívar Cabascango Rubio

Raúl Maya Andrade

Alfredo N. Montaivo Males

Plutarco Cisneros Andrade,
DIRECTOR GENERAL



**AUSPICIO ESPECIAL:
BANCO CENTRAL DEL ECUADOR**

<i>Dr.</i>	<i>Ricardo Muñoz Chávez</i>	<i>Ex presidente de la Junta Monetaria</i>
<i>Abog.</i>	<i>León Roldos Aguilera</i>	<i>Ex-presidente de la Junta Monetaria</i>
<i>Dr.</i>	<i>Rodrigo Espinosa Bermeo</i>	<i>Ex-Gerente General</i>
<i>Econ.</i>	<i>Germánico Salgado Peñaherrera</i>	<i>Ex-Gerente General</i>
<i>Dr.</i>	<i>Gonzalo Cordero Crespo</i>	<i>Presidente de la Junta Monetaria</i>
<i>Econ.</i>	<i>Mauricio Dávalos Guevara</i>	<i>Gerente General</i>
<i>Lcdo.</i>	<i>Eduardo Samaniego Salazar</i>	<i>Subgerente General</i>

5



EDITOR:

Instituto Otavaleño de Antropología — 1981 —

Casilla 1478

Otavalo-Ecuador

CONSEJO EDITORIAL:

Plutarco Cisneros Andrade

Segundo Moreno Yáñez

Juan Freile Granizo

Carlos Benavides Vega

Fernando Plaza Schuller

Simón Espinosa Cordero

Patricio Guerra Guerra

Hernán Jaramillo Cisneros

Carlos Coba Andrade

Francisco Aguirre Vásconez

José Echeverría Almeida

COMITE EDITORIAL:

Plutarco Cisneros Andrade

Segundo Moreno Yáñez

Carlos Benavides Vega

Simón Espinosa Cordero

COORDINADOR GENERAL:

Juan Freile Granizo

DIRECTOR GENERAL: *Plutarco Cisneros Andrade*

DIAGRAMACION Y DISEÑO:

Julio O. Flores R.

Edwin Rivadeneira

IMPRESION:

Editorial "Gallocapitán"

Otavalo - Ecuador



(Compilador) :

Udo Oberem

COCHASQUI:

Estudios Arqueológicos

Serie: Arqueología

*** * ***



Reseña de cuadros,
tablas, fotos y planos

Con el objeto de presentar a los estudiosos de la Arqueología ecuatoriana se ha creído conveniente editar, parte de los materiales gráficos del Proyecto Cochasquí en este volumen.

Es importante anotar que sus autores han sido el Arq. Wolfgang Wurster, Jürgen Wentscher y Julio César Cubillos. Los dibujos correspondientes al estudio de la "Cerámica fina y hallazgos nuevos de Cochasquí", fueron realizados por U. Schönfelder.

INDICE GENERAL

CUADROS	13
TABLAS	37
LAMINAS FOTOGRAFICAS	97
PLANOS	173

CUADROS

INDICE DE CUADROS

- cuadro A cuadro de seriación de las formas de decoración en complejos estratigráficamente diferenciables
- cuadro B cuadro de seriación de las formas de decoración en complejos estratigráficamente diferenciables
- cuadro C cuadro de seriación de los tipos de borde de complejos estratigráficamente diferenciables o no diferenciables
- cuadro D cuadro de seriación de los tipos de base, objetos foráneos e imitaciones incaicas de complejos estratigráficamente diferenciables o no diferenciables
- cuadro E cuadro de combinación: formas de borde de decoración de los ejemplares de colecciones y museos
- cuadro F cuadro de combinación: tipos de borde de decoración según figuras fotográficas (Porras 1975, Jijón y Caamaño 1952)
- cuadro G cuadro de combinación: tipos de borde de decoración de los hallazgos de Cochacuí
- cuadro H cuadro de seriación de las figurinas, vasijas antropo—/zoomorfas etc., discos cerámicos, artefactos de concha y de hueso de complejos estratigráficamente diferenciables o no diferenciables

- cuadros I — 0 tipos de vasija, ordenados según tipos de borde, de la excavación de Cochasquí, colecciones, museos, publicaciones: Jijón y Caamaño 1952 y Porras 1975
- cuadro P cuadro de correlación: tipos de borde tipos de decoración con su supuesto ordenamiento cronológico
- cuadro Q distribución en forma de fases de los huesos de animales de Cochasquí
- cuadro R cuadro cronológico de Imbabura y las provincias del norte de Pichincha según Athens 1978: Table 10
- cuadro S cuadro cronológico según Athens 1978 (sobre regional), Meyers 1975 / Schönfelder 1981 (regional), Imbabura y provincias del norte de Pichincha

	Substrat				Prokolorierung				Form-Bearbeitung				Aus- u. weite Bearbeitung				Zusatzstoffe				Verfahrenstechnik				Zusätzliche Bemerkungen							
	1	2	3	4	5	6	7	8	9	10	11	12	13	14	15	16	17	18	19	20	21	22	23	24	25	26	27	28				
HÜGEL I/II	■																												■	■	■	■
HÜGEL III																																
HÜGEL IV																																
HÜGEL V	■																															
HÜGEL VI	■																															
HÜGEL VII	■																															
HÜGEL VIII	■																															
HÜGEL IX	■																															
HÜGEL X																																
HÜGEL XI																																
HÜGEL XII																																
HÜGEL XIII																																
HÜGEL XIV																																
HÜGEL XV																																
HÜGEL XVI																																
HÜGEL XVII																																
HÜGEL XVIII																																
HÜGEL XIX																																
HÜGEL XX																																
HÜGEL XXI																																
HÜGEL XXII																																
HÜGEL XXIII																																
HÜGEL XXIV																																
HÜGEL XXV																																
HÜGEL XXVI																																
HÜGEL XXVII																																
HÜGEL XXVIII																																
HÜGEL XXIX																																
HÜGEL XXX																																
HÜGEL XXXI																																
HÜGEL XXXII																																
HÜGEL XXXIII																																
HÜGEL XXXIV																																
HÜGEL XXXV																																
HÜGEL XXXVI																																
HÜGEL XXXVII																																
HÜGEL XXXVIII																																
HÜGEL XXXIX																																
HÜGEL XL																																
HÜGEL XLI																																
HÜGEL XLII																																
HÜGEL XLIII																																
HÜGEL XLIV																																
HÜGEL XLV																																
HÜGEL XLVI																																
HÜGEL XLVII																																
HÜGEL XLVIII																																
HÜGEL XLIX																																
HÜGEL L																																

MADE IN GERMANY

A

A cuadro de seriación de las formas de decoración en complejos estratigráficamente diferenciables.

A 3 307 1820 mm

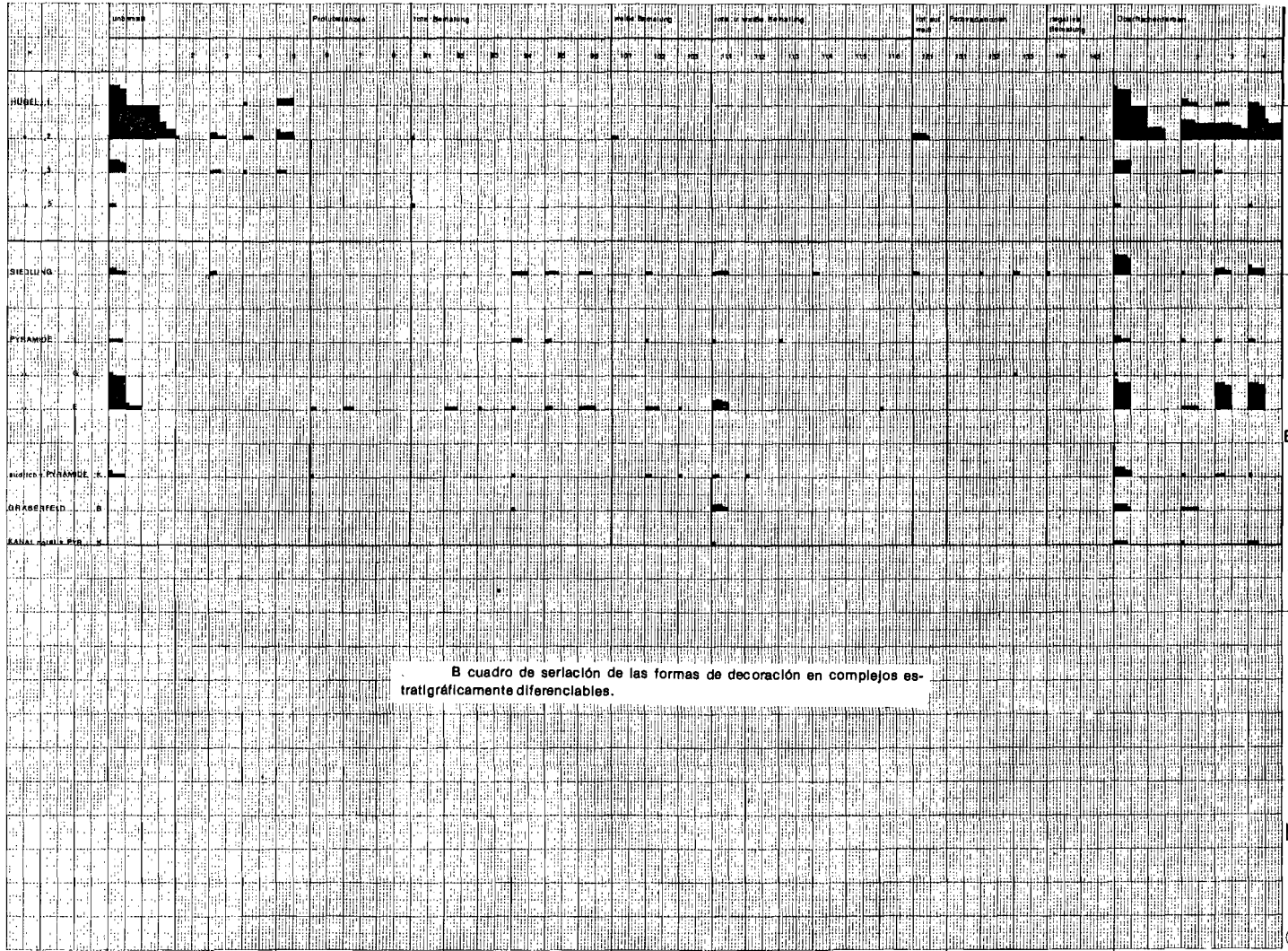

B

B. Quadro de serlação de las formas de decoração en complexos estratigráficamente diferenciáveis.

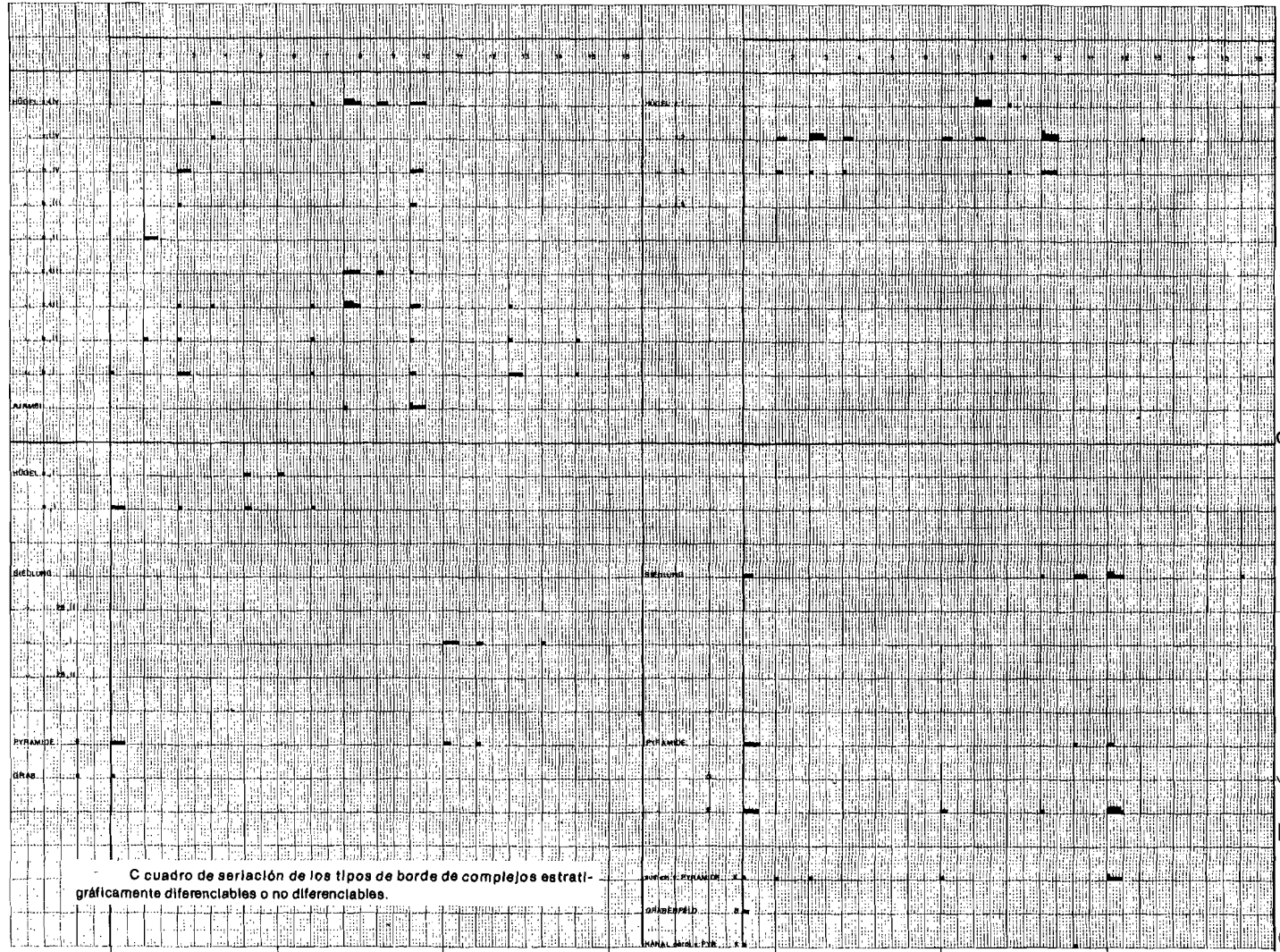

C cuadro de seriación de los tipos de borde de complejos estratigráficamente diferenciables o no diferenciables.

D cuadro de seriación de los tipos de base, objetos foráneos e limitaciones incaicas de complejos estratigráficamente diferenciables o no diferenciables.

ANEXOS: MAPA DEL MANTENIMIENTO

TURCA
INCA
MAYA

TURCA
INCA
MAYA

HIGH LAY

HIGH LAY

HIGH LAY

HIGH LAY

MID LAY

MID LAY

MID LAY

MID LAY

LOW LAY

LOW LAY

LOW LAY

LOW LAY

BASE

BASE

BASE

BASE

FOUNDATION

FOUNDATION

FOUNDATION

FOUNDATION

FOUNDATION

FOUNDATION

FOUNDATION

FOUNDATION

FOUNDATION

FOUNDATION

FOUNDATION

FOUNDATION

FOUNDATION

FOUNDATION

FOUNDATION

FOUNDATION

FOUNDATION

FOUNDATION

FOUNDATION

FOUNDATION

FOUNDATION

FOUNDATION

FOUNDATION

FOUNDATION

FOUNDATION

FOUNDATION

FOUNDATION

FOUNDATION

FOUNDATION

FOUNDATION

FOUNDATION

FOUNDATION

FOUNDATION

FOUNDATION

FOUNDATION

FOUNDATION

FOUNDATION

FOUNDATION

FOUNDATION

FOUNDATION

FOUNDATION

FOUNDATION

FOUNDATION

FOUNDATION

FOUNDATION

FOUNDATION

FOUNDATION

FOUNDATION

FOUNDATION

FOUNDATION

FOUNDATION

FOUNDATION

FOUNDATION

FOUNDATION

FOUNDATION

FOUNDATION

FOUNDATION

FOUNDATION

FOUNDATION

FOUNDATION

FOUNDATION

FOUNDATION

FOUNDATION

FOUNDATION

FOUNDATION

FOUNDATION

FOUNDATION

FOUNDATION

FOUNDATION

FOUNDATION

FOUNDATION

FOUNDATION

FOUNDATION

FOUNDATION

MADE IN GERMANY

D



A 3 397 1420 mm



Número	Forma del borde					Forma de la decoración					Forma del fondo					Forma de la impresión		
	1	2	3	4	5	1	2	3	4	5	1	2	3	4	5	1	2	3
1																		
2																		
3																		
4																		
5																		
6																		
7																		
8																		
9																		
10																		
11																		
12																		
13																		
14																		
15																		
16																		
17																		
18																		
19																		
20																		
21																		
22																		
23																		
24																		
25																		
26																		
27																		
28																		
29																		
30																		
31																		
32																		
33																		
34																		
35																		
36																		
37																		
38																		
39																		
40																		
41																		
42																		
43																		
44																		
45																		
46																		
47																		
48																		
49																		
50																		
51																		
52																		
53																		
54																		
55																		
56																		
57																		
58																		
59																		
60																		
61																		
62																		
63																		
64																		
65																		
66																		
67																		
68																		
69																		
70																		
71																		
72																		
73																		
74																		
75																		
76																		
77																		
78																		
79																		
80																		
81																		
82																		
83																		
84																		
85																		
86																		
87																		
88																		
89																		
90																		
91																		
92																		
93																		
94																		
95																		
96																		
97																		
98																		
99																		
100																		

E cuadro de combinación: formas de borde decoración de los ejemplares de colecciones y museos.

Línea	Figura		Borde Decoración						Forma de la Borde Decoración						Figura de la Borde Decoración		Forma de la Borde Decoración		
	Figura	Figura	Figura	Figura	Figura	Figura	Figura	Figura	Figura	Figura	Figura	Figura	Figura	Figura	Figura	Figura	Figura	Figura	Figura
1																			
2																			
3																			
4																			
5																			
6																			
7																			
8																			
9																			
10																			
11																			
12																			
13																			
14																			
15																			
16																			
17																			

F cuadro de combinación: tipos de borde decoración según figuras fotográficas (Porras 1975, Jijón y Caamaño 1952).

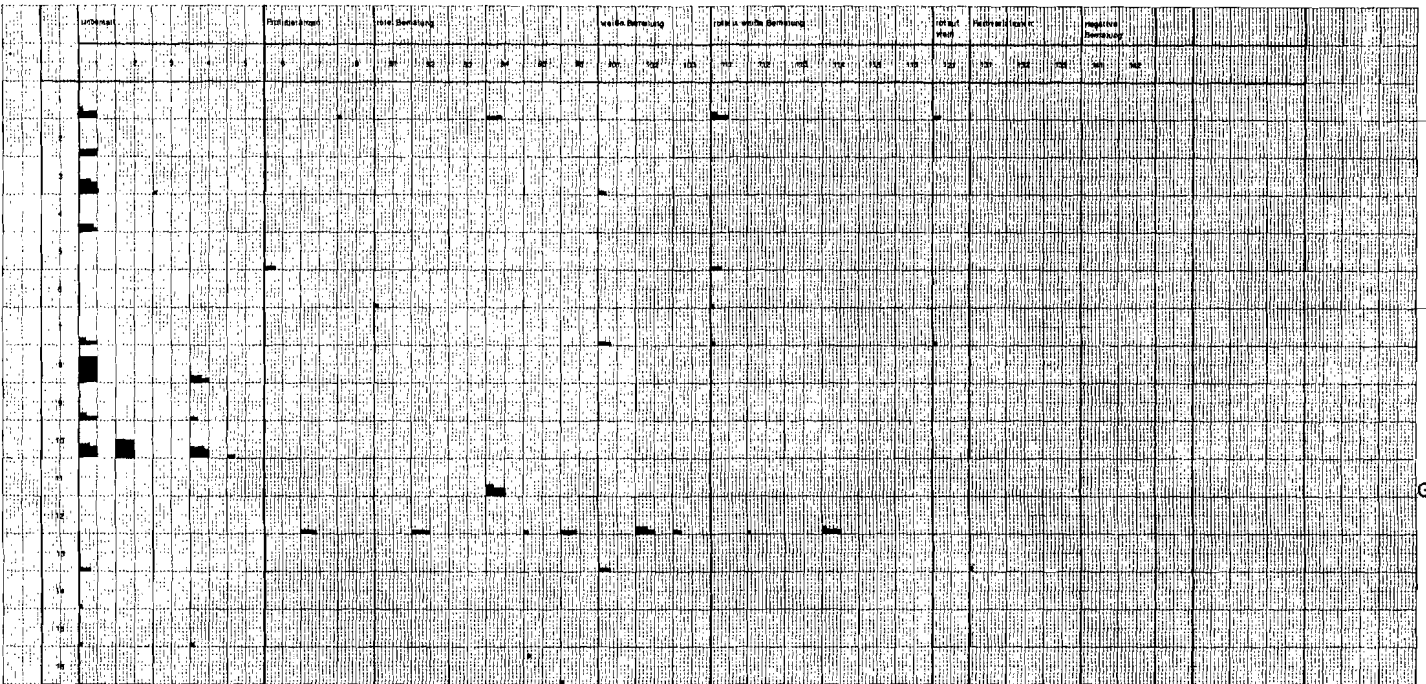







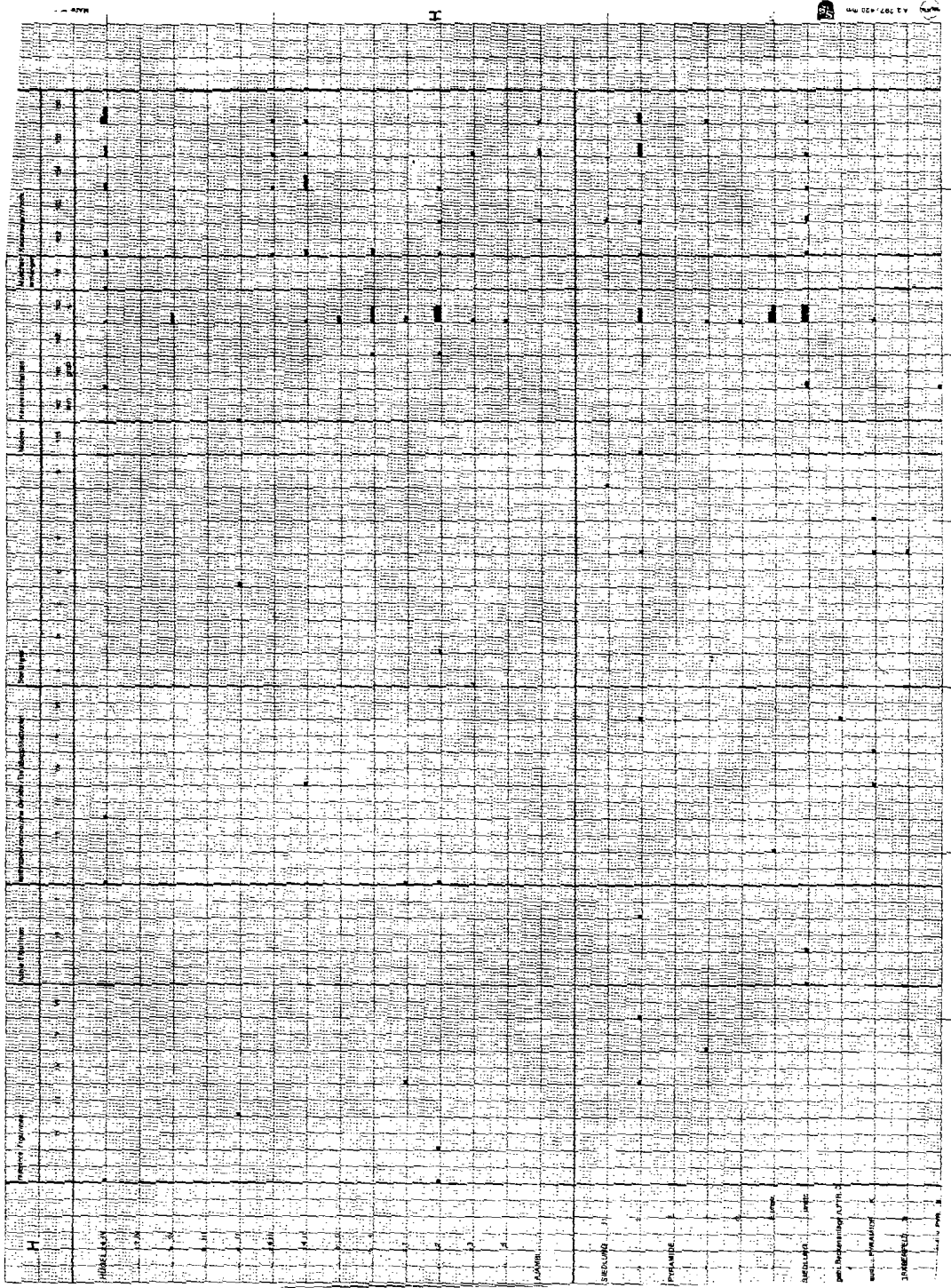











































Made in Germany

G













G cuadro de combinación: tipos de borde-decoración de los hallazgos de Cochasqui.



H cuadro de gerlación de las figurinas, vasijas antropo-/zoomorfas etc., discos cerámicos, artefactos de concha y de hueso de complejos estratigráficos diferenciables.

FAMILIA	DEFORMACIONES (MODERN)										REFINADO
	 Co 3142 Hagen 1917 Taf. 102, Abb. 12 Museo, Roman Park, Hagen 1917	 Co 614 Hagen 1917 Taf. 102, Abb. 12 Museo, Roman Park, Hagen 1917	 Co 617 Hagen 1917 Taf. 102, Abb. 12 Museo, Roman Park, Hagen 1917	 Co 618 Hagen 1917 Taf. 102, Abb. 12 Museo, Roman Park, Hagen 1917	 Co 619 Hagen 1917 Taf. 102, Abb. 12 Museo, Roman Park, Hagen 1917	 Co 620 Hagen 1917 Taf. 102, Abb. 12 Museo, Roman Park, Hagen 1917	 Co 621 Hagen 1917 Taf. 102, Abb. 12 Museo, Roman Park, Hagen 1917	 Co 622 Hagen 1917 Taf. 102, Abb. 12 Museo, Roman Park, Hagen 1917	 Co 623 Hagen 1917 Taf. 102, Abb. 12 Museo, Roman Park, Hagen 1917	DEFORMADO	
	 Museo, Banco Central Taf. X, Abb. 1 Museo, Banco Central	 Museo, Banco Central Taf. X, Abb. 2 Museo, Banco Central	 Museo, Banco Central Taf. X, Abb. 3 Museo, Banco Central	 Museo, Banco Central Taf. X, Abb. 4 Museo, Banco Central	 Museo, Banco Central Taf. X, Abb. 5 Museo, Banco Central	 Museo, Banco Central Taf. X, Abb. 6 Museo, Banco Central	 Museo, Banco Central Taf. X, Abb. 7 Museo, Banco Central	 Museo, Banco Central Taf. X, Abb. 8 Museo, Banco Central	 Museo, Banco Central Taf. X, Abb. 9 Museo, Banco Central	CANTON, BOLIVIA, BOLIVIA	
	 Co 3151 Hagen 1917 Taf. 102, Abb. 13 Museo, Roman Park, Hagen 1917	 Co 3152 Hagen 1917 Taf. 102, Abb. 13 Museo, Roman Park, Hagen 1917	 Co 3153 Hagen 1917 Taf. 102, Abb. 13 Museo, Roman Park, Hagen 1917	 Co 3154 Hagen 1917 Taf. 102, Abb. 13 Museo, Roman Park, Hagen 1917	 Co 3155 Hagen 1917 Taf. 102, Abb. 13 Museo, Roman Park, Hagen 1917	 Co 3156 Hagen 1917 Taf. 102, Abb. 13 Museo, Roman Park, Hagen 1917	 Co 3157 Hagen 1917 Taf. 102, Abb. 13 Museo, Roman Park, Hagen 1917	 Co 3158 Hagen 1917 Taf. 102, Abb. 13 Museo, Roman Park, Hagen 1917	 Co 3159 Hagen 1917 Taf. 102, Abb. 13 Museo, Roman Park, Hagen 1917	CANTON, BOLIVIA, BOLIVIA	
	 Fam. I Fig. 200 Museo, Roman Park, Hagen 1917	 Fam. II Fig. 201 Museo, Roman Park, Hagen 1917	 Fam. III Fig. 202 Museo, Roman Park, Hagen 1917	 Fam. IV Fig. 203 Museo, Roman Park, Hagen 1917	 Fam. V Fig. 204 Museo, Roman Park, Hagen 1917	 Fam. VI Fig. 205 Museo, Roman Park, Hagen 1917	 Fam. VII Fig. 206 Museo, Roman Park, Hagen 1917	 Fam. VIII Fig. 207 Museo, Roman Park, Hagen 1917	 Fam. IX Fig. 208 Museo, Roman Park, Hagen 1917	CANTON, BOLIVIA, BOLIVIA	
	 Fam. X Fig. 209 Museo, Roman Park, Hagen 1917	 Fam. XI Fig. 210 Museo, Roman Park, Hagen 1917	 Fam. XII Fig. 211 Museo, Roman Park, Hagen 1917	 Fam. XIII Fig. 212 Museo, Roman Park, Hagen 1917	 Fam. XIV Fig. 213 Museo, Roman Park, Hagen 1917	 Fam. XV Fig. 214 Museo, Roman Park, Hagen 1917	 Fam. XVI Fig. 215 Museo, Roman Park, Hagen 1917	 Fam. XVII Fig. 216 Museo, Roman Park, Hagen 1917	 Fam. XVIII Fig. 217 Museo, Roman Park, Hagen 1917	CANTON, BOLIVIA, BOLIVIA	











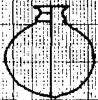











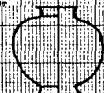

1 tipos de vasija, ordenados según tipos de borde, de la excavación de Cochasquí, colecciones, museos, publicaciones: Jijón y Caamaño 1952 y Porras 1975.

			BANCITWEN			SOPHARIBANDU			SOPHARIBANDU			
)			BANKILUNGEN II, MUSEO)			MUSEO JIJÓN Y CAAMAÑO			
	No.	TAP IX TAB. 1					No.		MUSEO JIJÓN Y CAAMAÑO			
			MUSEO PORRAS, MUSEO						MUSEO PORRAS, MUSEO			
TAP. IX												
)			GRABADO			}			GRABADO			
	Coche						Coche		GRABADO			
	Museo	TAP VIII TAB. 1					Museo	TAP VIII TAB. 1		GRABADO		
)				CELESTINO PORRAS, MUSEO)		GRABADO			
	Fig. 27	Fig. 28	Fig. 29					Coche - Museo	GRABADO			
								Museo - Museo	GRABADO			
			MUSEO PORRAS, MUSEO			}				MUSEO		
	TAP. IX	TAB. 1					No. 1	No. 2	No. 3	MUSEO		
	Fig. 30	Fig. 31					Fig. 32	Fig. 33	Fig. 34	MUSEO		
			GRABADO			}		MUSEO PORRAS, MUSEO				
	Coche							MUSEO PORRAS, MUSEO				
	Museo	TAP IX TAB. 1							MUSEO PORRAS, MUSEO			











J tipos de vasija, ordenados según tipos de borde, de la excavación de Cochasquí, colecciones, museos, publicaciones: Jijón y Caamaño 1952 y Porras 1975.

MADE IN GERMANY













A 3 287 420 mm

APERTURA	APLICACIONES								REFERENCIAS
									MUSEO, MUSEO Y PUBLICACIONES
CoDe:	TAP VI ABB 1	Museo Banco Central	TAP VI ABB 1	Bo:	TAP VI ABB 2	Bo:	TAP VI ABB 4		
									
Museo Banco Central	TAP VII ABB 3	M.B.C.	TAP VII ABB 3	M.B.C.	TAP IX ABB 3	M.B.C.	TAP IX ABB 2	TAP VII ABB 3	TAP VII ABB 3
									
CoDe:	TAP VII ABB 3	CoDe:	TAP VII ABB 3	Bo:	TAP IX ABB 1	P:	TAP VII ABB 3		
Fig. 31		Fig. 31						Fig. 31-32, 33-34, 35-36	K
Fig. 31								Porrás, Porrás y	
Taf. 10a	Taf. 10a	Taf. 10a	Taf. 10a					Porrás, Porrás y	
Parr. I		Parr. II						Porrás, Porrás y	K
Fig. 189		Fig. 189						Porrás, Porrás y	K























K tipos de vasija, ordenados según tipos de borde, de la excavación de Cochasqui, colecciones, museos, publicaciones: Jijón y Caamaño 1952 y Porrás 1975.

BORDOS	DESCRIPCIÓN				REFERENCIA
					10. 11. 12.
	ARCHA 172 (Fig. 13) Mound of Huay 1	TAP. IV MUSEO			
					13. 14. 15. 16.
	TAP. IV 10 MUSEO	TAP. IV 10 MUSEO	TAP. IV 10 MUSEO	TAP. IV 10 MUSEO	17. 18. 19. 20.
	Fig. 20	Fig. 21			21. 22. 23. 24.
					25. 26. 27. 28.
	Fig. 29				29. 30. 31. 32.









L tipos de vasija, ordenados según tipos de borde, de la excavación de Cochasqui, colecciones, museos, publicaciones: Jijón y Caamaño 1952 y Porras 1975.

BORDOS	DEFORMACIONES		RESUMIO
1			SANKILINEN, J. NISPERI.
Museo Banco Central	TAF. IV ABR. 2	No. TAF. IV ABR. 3	
			ZEPEDANO, HORRAC 1975.
Fig. 51	Fig. 52		
			FOTOS, HORRAC 1975.
Tel. 500	Tel. 500	Tel. 571	
			FOTOS, JIJÓN Y CAAMAÑO 1952.
Part. II	Fig. 46		
2			ZEPEDANO, HORRAC 1975.
Fig. 20	Fig. 20		
			SANKILINEN, J. NISPERI.
Museo Banco Central	TAF. IV ABR. 3		

M tipos de vasija, ordenados según tipos de borde, de la excavación de Cochasqui, colecciones, museos, publicaciones: JIJÓN y Caamaño 1952 y Porras 1975.

BANDJYP	GEFÄSSGEWÄN					HERKUNFT
						BEICHENHO, PORRAS 1975
Fig. 9	Fig. 10	Fig. 11	Fig. 12	Fig. 12		
						BEICHENHO, PORRAS 1975
Fig. 14	Fig. 15					
						BÄCKELMANN U. MERTEN
Bo	Taf. XII Abb. 1	Museo Museo Central Taf. XII Abb. 2	Bo	Taf. XII Abb. 2	Taf. XII Abb. 2	Taf. XII Abb. 3
						
Bo	Taf. XII Abb. 1	Bo	Taf. XII Abb. 3			
						FOTON, RUMKAS (1975)
Taf. 30	Taf. 30	Taf. 30	Taf. 30	Taf. 30	Taf. 30	

N tipos de vasija, ordenados según tipos de borde, de la excavación de Cochasquí, colecciones, museos, publicaciones: Jijón y Caamaño 1952 y Porras 1975.

TIPO DE BORDO	DESCRIPCIÓN	REFERENCIAS
		SAMPAL NORC II MUSEO
Fig. 10 	Fig. 11 	ZEICHNUNGEN PORRAS 1975
Fig. 10 	Fig. 11 	POTAS, PORRAS, JIJÓN
Fig. 10		
		SAMPAL NORC II MUSEO
Museo Renta: Central TAP. XIV plata 2	Museo Banco Central TAP. XIV plata 2	

O tipos de vasija, ordenados según tipos de borde, de la excavación de Cochaspil, colecciones, museos, publicaciones: Jijón y Caamaño 1952 y Porras 1975.

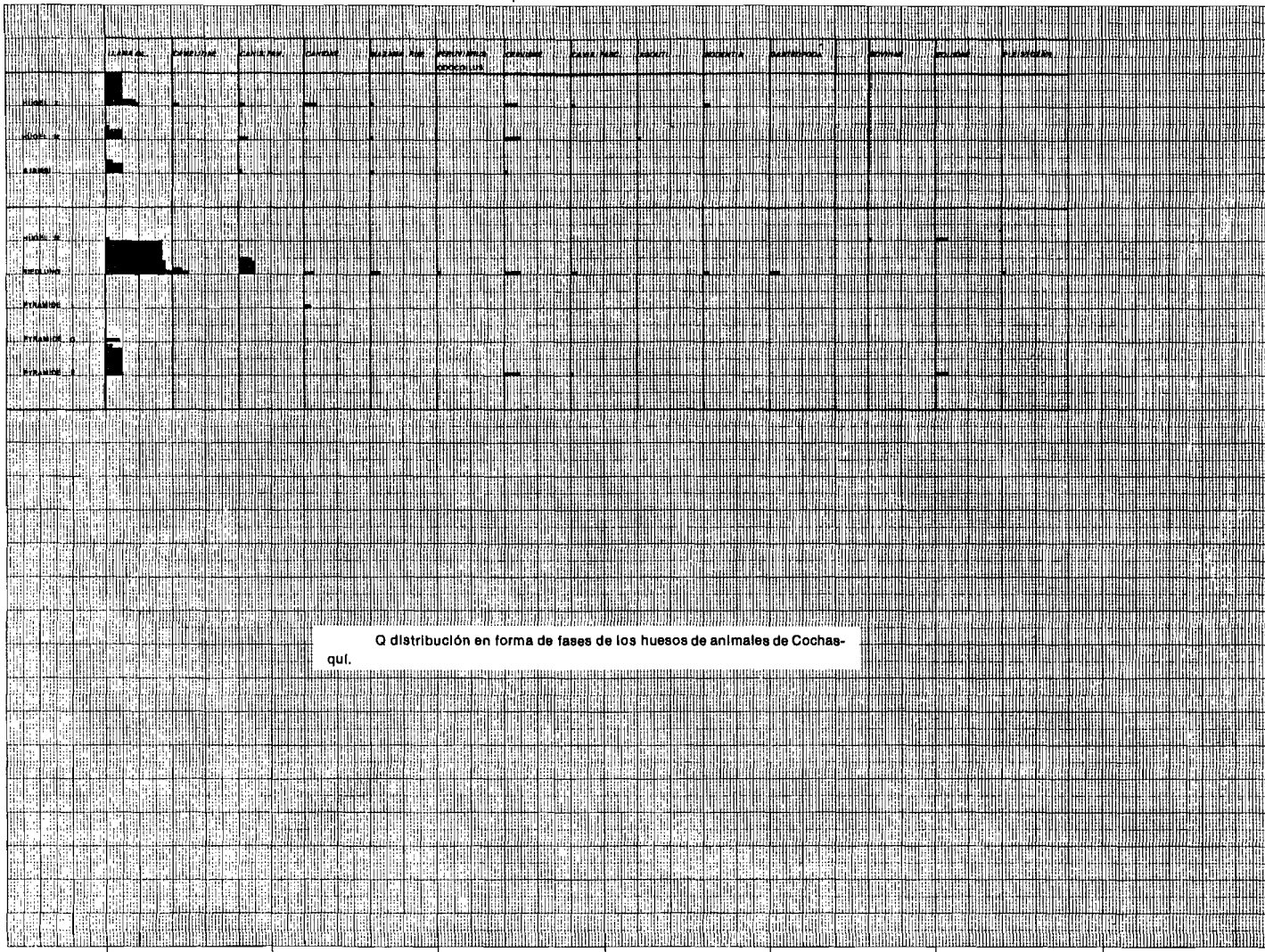

Q distribución en forma de fases de los huesos de animales de Cochacqui.

· R cuadro cronológico de Imbabura y las provincias del norte de Pichincha según Athens 1978: Table 10.

Período	Fechas estimadas	Elementos diagnósticos	Sitio y procedencia de la documentación	Cómo se documentó	Otros rasgos	Comentarios
Incaico	D.C. 1534–1525	arquitectura y cerámica	Caranqui	Fuentes históricas	—	—
Tardío	D.C. 1525–1250	montículos con rampa y ánforas con pintura roja	Pínsaquí No. 1 Socapamba No. 15, 21 Cochasquí E	C-14	montículos cuadriláteros y hemisféricos, cerámica Tuza	“Tolas habitaciones” de J. y C.
6	D.C. 1250–1000	vasijas zapatiformes, comienza el uso de engobe color herrumbre, Cerámica fina pintada	Cochasquí; niveles superiores de Socapamba No. 18	C-14	montículos habitacionales y de enterramientos	“Tolas con Pozo” de J. y C.
5	D.C. 1000–700	comp. con perfil de bordes ondulados, plato con borde somero e interior de engobe rojo y pulido	Socapamba No. 19	C-14	montículos de enterramientos y habitacionales, cerámica fina anaranjada posiblemente diagnóstica	
4	D.C. 700–200	platos y jarras con pintura positiva	La Chimba, corte 4	Estratigrafía	artefactos de conchas marinas, pintura negativa, vasijas trípodes, botellas con asa y puente	primer uso de pintura roja; probable inicio de la construcción de montículos
3	D.C. 200– A.C. 200	platos con incisiones exteriores diagonales	La Chimba, corte 4	C-14	figurilla mascando coca	platos a menudo carinados que pueden tener zonas de engobe blanco y/o pastillaje
2	A.C. 200–600	platos con motivo dentado exterior bajo el plano saliente del labio	La Chimba, corte 4	Estratigrafía	igual que los periodos 3 y 4	
1	A.C. 600–1000	platos posiblemente carinados con protuberancias en el hombro, y pequeñas ollas de base plana con bruñido vertical	Im 11, corte e, y enterramiento 1	C-14	maíz, frejol, huecos en forma de campana, enterramientos en pozos con cámara lateral, cerámica de rasgos estilísticos generalizados, engobe rojo, tizne negro, pintura negativa, compoteras	período “Pozo” de J. y C.

COCHASQUI (REGIONAL)

SUPRAREGIONAL

Athens, 1978 (cfr. Tab. R)	Meyers, 1975	Tipos Diagnósticos	Estructuras Diagnósticas	Schönfelder, 1979	Tipos cerámicos diagnósticos	Estructuras Diagnósticas
INCAICO 1525 -- 1534 ----- TARDIO 1250 1525	Cochasquí II	trípodes ánforas pintura de color	Pirámides montículos	Cochasquí II	Cerámica gruesa tipos del período tardío de Athens y Meyers (Cochasquí II) Cerámica Fina objetos pintados (determinados tipos)	Pirámides, pisos quemados in situ (montículos funerarios?)
6 1000 – 1250	Cochasquí I	Ollas zapatiformes	Estratos bajo los montículos	Cochasquí I/II	Cerámica gruesa Tipos del Período 6 de Athens y Meyers (Cochasquí I) Cerámica Fina Objetos período cara pintados (Determinados tipos)	Inicio de pirámides? Montículos funerarios Recipientes
5 700 – 1000				Cochasquí I	Cerámica gruesa Tipos del período 5 de Meyers y Athens (Cochasquí I?) Cerámica fina objetos no-pintados objetos pintados al comienzo del P.C (Tipos deter- minados)	Pisos secados al aire zanjas

S cuadro cronológico según Athens 1978 (sobre regional), Meyers 1975 /
Schönfelder 1981 (regional), Imbabura y provincias del norte de Pichincha

TABLAS

INDICE DE TABLAS

Tab. I	tipos de borde 1 – 10
Tab. II	tipos de borde 11 – 16, tipos de base 1 – 4
Tab. III	fig. 1 – 5 tipos de decoración 1, 2, 3, 4, 9, 1, fase I
Tab. IV	fig. 1 -- 6 tipos de decoración 9.2, 9.5, 9.6, 10.2, 10.3, 11.3 fase II
Tab. V	fig. 1 – 3 cerámica tosca de Socapamba (Im 10) mound 18 (upper levels) y mound 19 según Athens 1978: fig. 13
Tab. VI-XVIII	Vasijas de colecciones privadas, museo y excavaciones (R. = tipo de borde, V. = tipo de decoración B. = tipo de base)
Tab. VI	fig. 1 – 4 R.: 4, v.: 12.1, fase I/II
Tab. VII	fig. 1 – 3 R.: 4, v.: 12.1, B.: 4, fase I/II
Tab. VII	fig. 4 R.: 4, V.: 4, B.: 4, fase I
Tab. VIII	fig. 1 R.: 4, V.: 12.1, B.: 4, fase I/II
Tab. VIII	fig. 2 R.: 4, V.: 9.1, B.: 4, fase I/II
Tab. VIII	fig. 3 R.: 4, V.: 12.1, B.: 4, fase I/II

Tab. VIII	fig. 4 R.: o/o, v.: 12.1, B.: 4, fase I/II
Tab. IX	fig. 1 – 3 R.: 4, V.: 10.1, B., 4 fase I
Tab. IX	fig. 4 R.: 4, V.: 1, B.: 4, fase I
Tab. X	fig. 1 R.: 1, V.: 9.4, B.: 2, fase II
Tab. X	fig. 2 R.: 1, V.: 11.1, B.: 2, fase II
Tab. X	fig. 3 R.: 1, V.: 9.1, B.: 2, fase I
Tab. X	fig. 4 R.: 1, V.: 14.2, B.: 2, fase I
Tab. XI	fig. 1 – 4 R.: 1, V.: 11.1, B.: 2, fase II
Tab. XII	fig. 1 – 3 R.: 13, V.: 4, 5, 10.1, B.: 1, fase I
Tab. XIII	fig. 1 R.: 12, V.: 7, B.: 1, fase II
Tab. XIII	fig. 2 R.: 13, V.: 4, 5, B.: 1, fase I
Tab. XIII	fig. 3 R.: 13, V.: 5, B.: 1, fase I
Tab. XIV	fig. 1 R.: 8, V.: 4, B.: 1, fase I
Tab. XIV	fig. 2 R.: 9, V.: 4, B.: 1, fase I
Tab. XIV	fig. 3, 4 R.: 9, V.: 4, B.: 1, fase I
Tab. XV	fig. 1 – 3 R.: 10, V.: 2, B.: 1, fase I
Tab. XVI	fig. 1 R.: 12, V.: 9.1, B.: 1, fase I
Tab. XVI	fig. 2 R.: 12, V.: 9.1, 9.5, B.: 1, fase I
Tab. XVI	fig. 3 R.: 12, V.: 9.3, B.: 1, fase II
Tab. XVII	fig. 1 R.: 15, V.: 10.1, B.: 1, fase I

- Tab. XVII fig. 2 R.: 13, V.: 10.1, B.: 1, fase I
- Tab. XVII fig. 3 R.: 1, V.: 9.4, B.: 2, fase II
- Tab. XVIII fig. 1 R.: 5, V.: 1, B.: 4, fase I
- Tab. XVIII fig. 2 R.: 2, V.: 2, B.: 1, fase I
- Tab. XIX-XXIV Hallazgos cerrados (descripción véase el capítulo IV, 1.17, pág. 144 – 158)
- Tab. XIX fig. 1 -- 3 (vasijas 2, 3, 5, 17) montículo n, fase I/II
- Tab. XX fig. 1 -- 6 (vasijas 4, 11, 12, 14, 15, 16) montículo n, fase I/II
- Tab. XXI fig. 1 -- 3 (vasijas 1, 6, 7, 13, 18, 19) montículo n, fase I/II
- Tab. XXII fig. 1 montículo a, fase I/II
- Tab. XXIII fig. 1 -- 3 montículo a, fase I/II
- Tab. XXIV fig. 4 -- 6 pueblo, corte 8, tumba 5, fase I o I/II?
- Tab. XXIV fig. 4 -- 6 montículo m, fase I/II o II (?)
- Tab. XXV-XXVII 1. comparación cerámica fina-tosca
2. cerámica foránea (tuza, inca)
- Tab. XXV fig. 1 -- 4 cerámica tosca, fase I
- Tab. XXVI fig. 1 -- 4 cerámica tosca, fase II
- Tab. XXVII fig. 1 cerámica tosca, fase II
- Tab. XXVII fig. 2, 3 objetos tuza, fase II

- Tab. XXVII fig. 4, 5, imitaciones objetos incaicas, fase II
- Tab. XXVIII-XXXII figurinas, vasijas antropo-/zoomorfos o aplicaciones de vasijas, silbatos, pendientes, modelos (arcilla), discos cerámicos, (descripción véase cap. IV, 1.3-1.5)
- Tab. XXVIII fig. 1 – 4 figurinas sólidas, tipos 1.3.1, I – III, fase I
- Tab. XXIX fig. 1 – 3 figurinas sólidas, tipos 1.3.1, IV – VI, fase I/II, II
- Tab. XXIX fig. 4, 5 figurinas huecas, tipos 1.3.2, I + II, fase II
- Tab. XXX fig. 1 figurina hueca, tipo 1.3.2, III fase II
- Tab. XXX fig. 2, 3, 4, 6, 7, 8, 9 tipos 1.3.3, I – IV, VI, vasijas o aplicaciones de vasijas antropo/zoomorfos (fig. 2-4, 7, 8 = fase I), fig. 5, 6, 9 = fase II)
- Tab. XXXI fig. 1 fragmento de pie sólido antropomorfo (?), tipo 1.3.3. V, fase II
- Tab. XXXI fig. 2 – 8 otros, 1.3.4, a, b, e, (fig. 3, 4 = fase I, fig. 2, 5 – 8 = fase II)
- Tab. XXXII fig. 1 – 3 otros 1.3.4 c, d, f (fig. 2, fase I, fig. 1, 3 = fase II)
- Tab. XXXII fig. 4 modelo, fase II
- Tab. XXXII fig. 5, 6 discos cerámicos, fase I + II
- Tab. XXXIII-XXXVII artefactos de hueso

Tab. XXXIII fig. 1–4 espátula, fase I

Tab. XXXIV fig. 1–3 espátula (fig. 1 = fase I, fig. 2, 3 = fase II)

Tab. XXXIV fig. 4–6 silbatos, fase I

Tab. XXXV fig. 1–7 puntas de hueso (fig. 1–6 = fase I, fig. 7 = fase II)

Tab. XXXVII fig. 4 punta de hueso, fase I

Tab. XXXVII fig. 2–10 artefactos con funciones de rayar, perforar, cortar (fig. 2, 3, 5, 7, 8, 10 – fase I, fig. 4, 6, 9 = fase II)

Tab. XXXVIII fig. 1, 2 "Computeras con wavy rim profile" (Computeras con pié y labio ondulado) fase I

Tab. I Tipos de borde 1-10

1

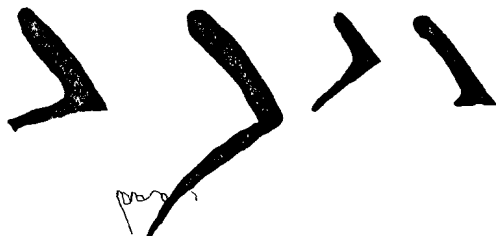

2



3

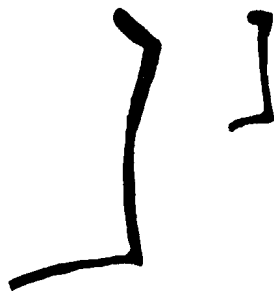

4



5



6



TAF. I



7



8



9



10





16



1



12



15



2



13



3



14



4



TAF. II

Tab. II tipos de borde 11-16, tipos de base 1-4

TAF III



1

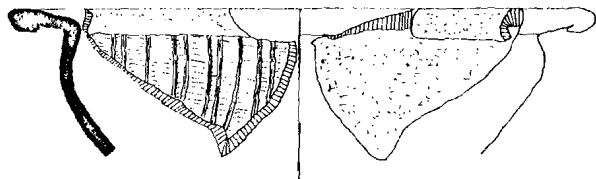

4

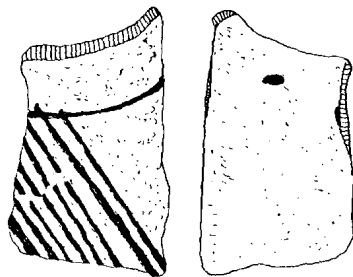

2



5

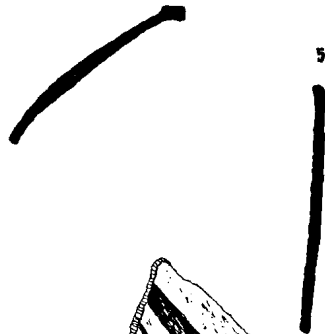

3

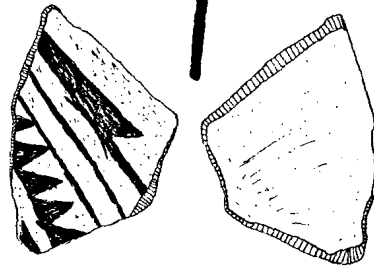
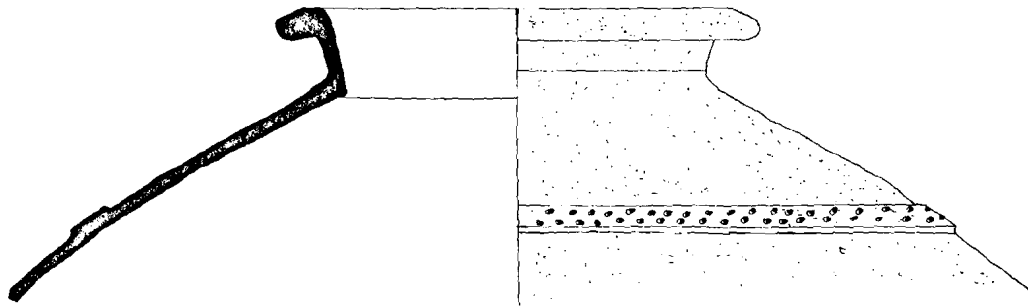

Tab. III fig. 1-5 tipos de decoración 1, 2, 3, 4, 9, 1, fase I



1

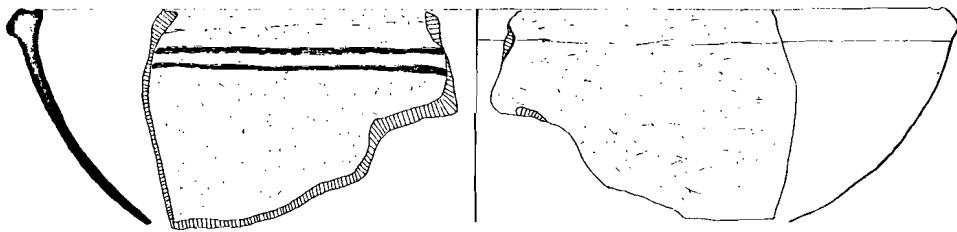

2

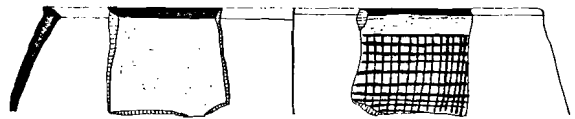

3

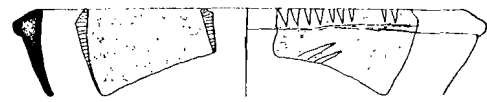

4

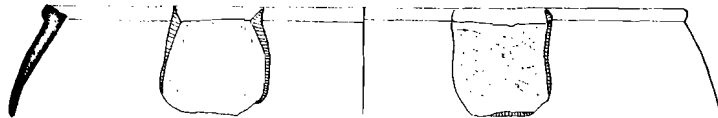

5

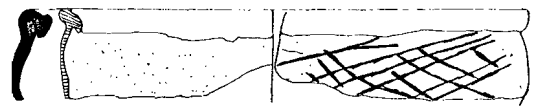

6

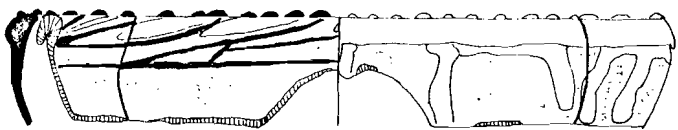

Tab. IV fig. 1-6 tipos de decoración 9.2, 9.5, 9.8, 10.2, 10.3, 11.3, fase II

Tab. V fig. 1-3 cerámica tosca de Socapamba (Im 10) mound 18 (upper levels) y mound 19 según Athens 1978: fig. 13



Abb. 1

Abb. 2

Abb. 3

Figure 13. Pottery vessels from Socapamba (Im 10) mound #18 (upper levels) and mound #19. Vessels "a" and "b" are from mound #18, burial #2, "a" being a tripod form with rust slip, and "b" a Thin Ware jar with negative paint. Vessels "c" and "d" are from an eroded hearth area of mound #18, cut 2, level 1, "c" being a shoe-shaped form and "d" a plain compotera. Vessels "e-j" are from mound #19, burial #6. Vessels "e", "f", and "h" illustrate the wavy rim type (with interior red slip and polish) and "j" is a plain Thin Ware compotera.

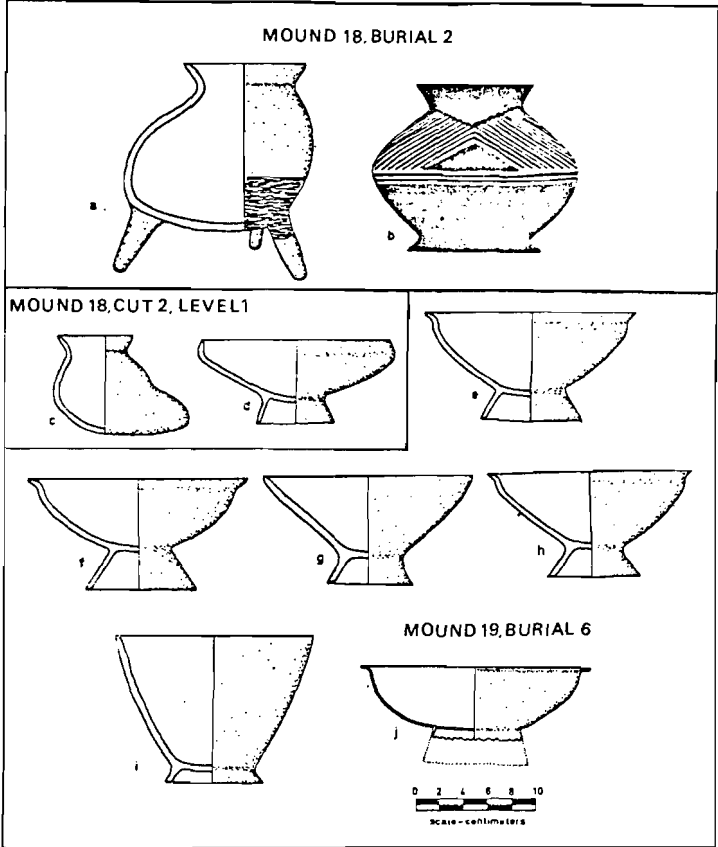
Tab. VI-XVIII Vasijas de colecciones privadas, museo y excavaciones (R. = tipo de borde, V. = tipo de decoración, B. = tipo de base)



1

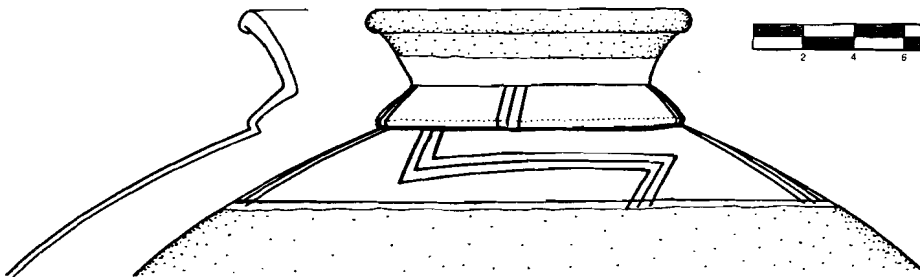

2

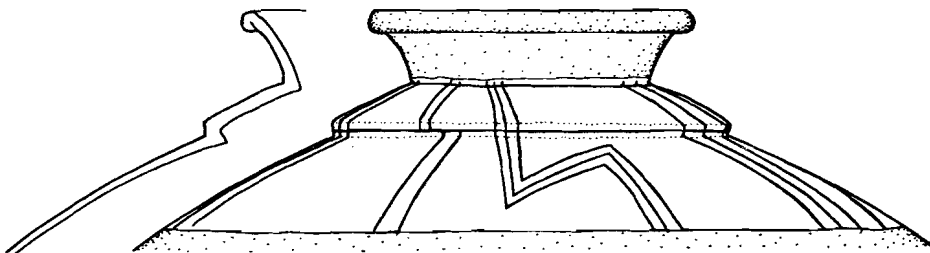

3

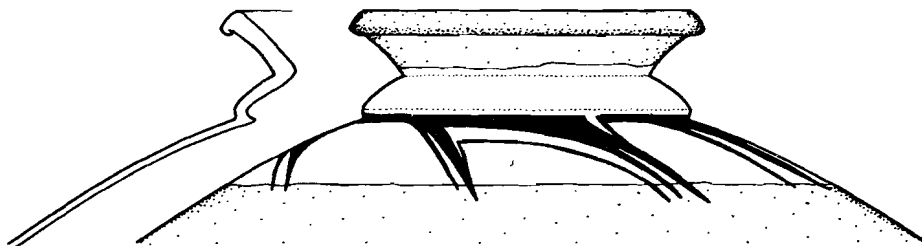

4

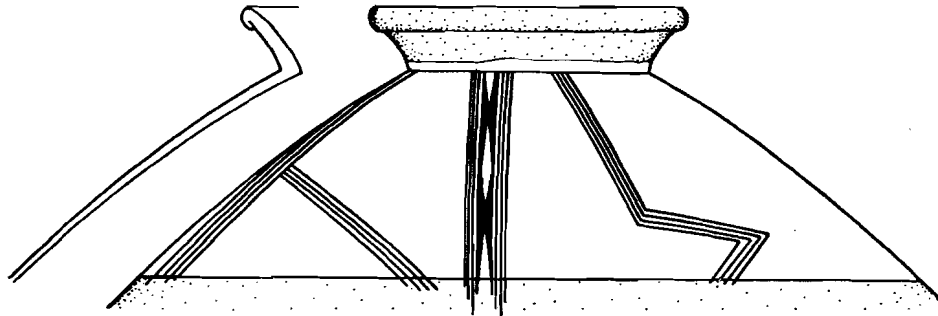

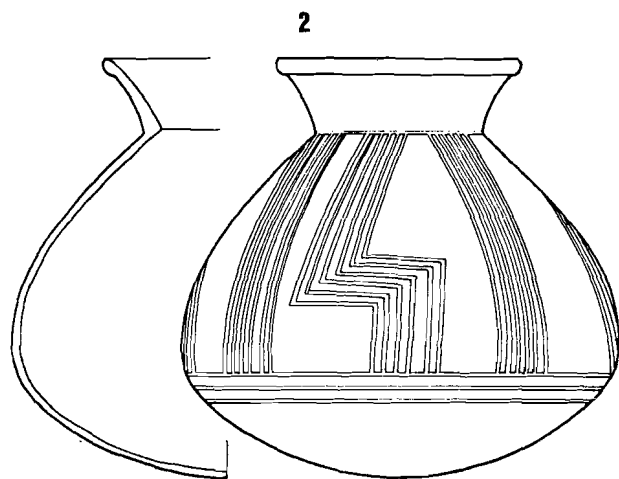
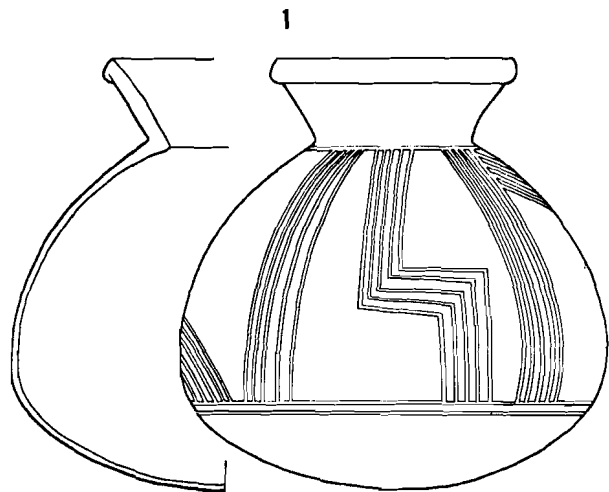

TAF VII

Tab. VII fig. 4 R.: 4, V.: 4, B.: 4, fase I

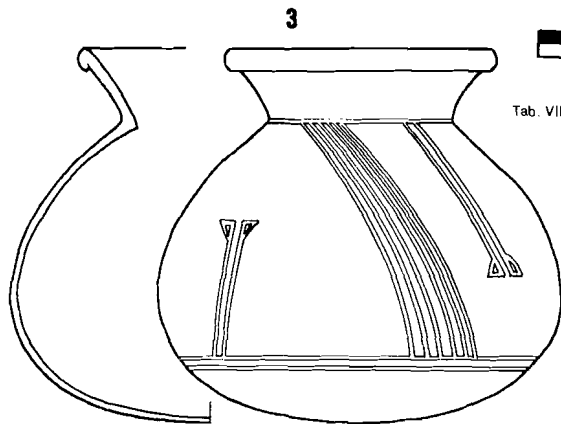

Tab. VII fig. 1-3 R.: 4, V.: 12, 1, B.: 4, fase I/III

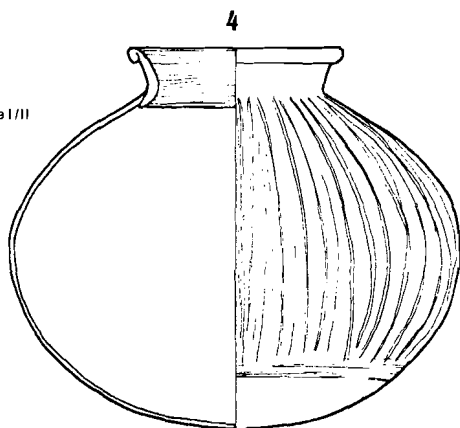

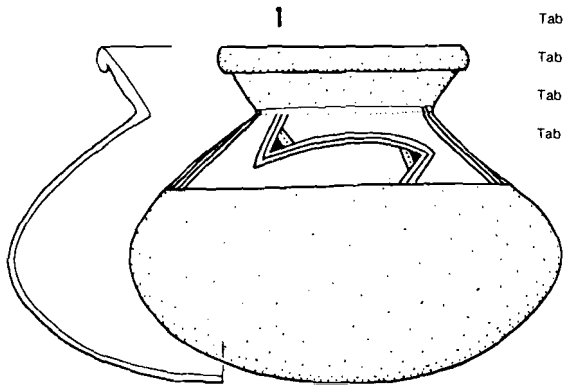

Tab. VIII fig. 1 R.: 4, V.: 12. 1, B.: 4, fase I/II

Tab. VIII fig. 2 R.: 4, V.: 9. 1, B.: 4, fase I/II

Tab. VIII fig. 3 R.: 4, V.: 12. 1 B.: 4, fase I/II

Tab. VIII fig. 4 R.: %, V.: 12, 1, B.: 4, fase I/II

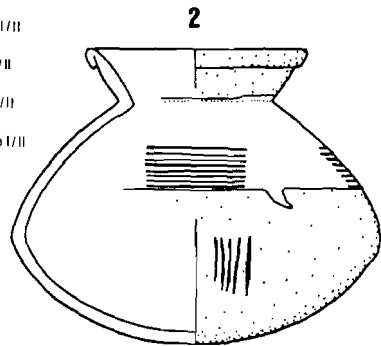

TAF. VIII

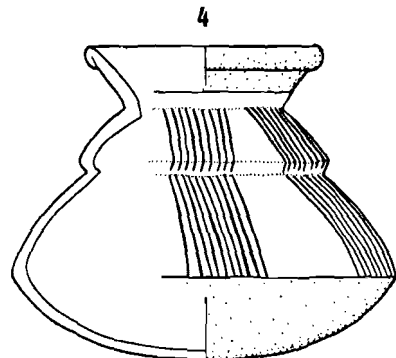
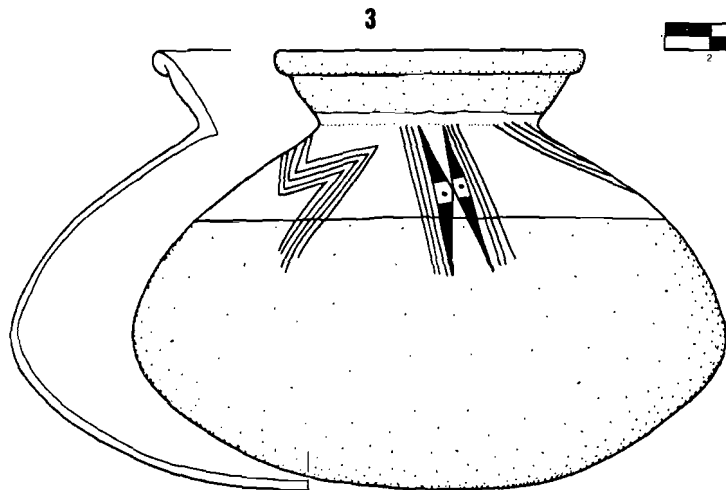

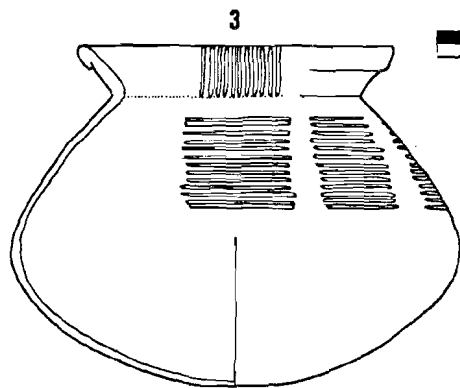
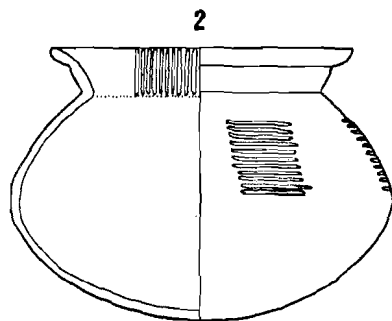
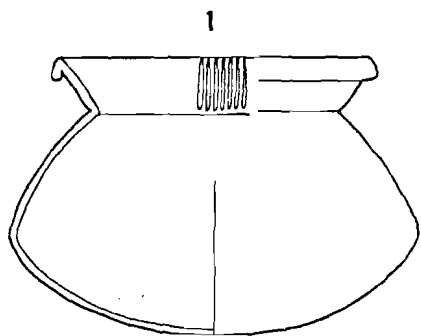

TAF IX

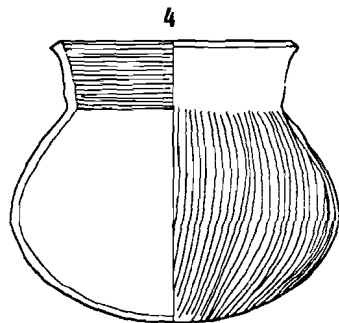

Tab. IX fig. 1-3 R.: 4, V.: 10.1, B.: 4, fase I

Tab. IX fig. 4 R.: 4, V.: 1, B.: 4, fase I

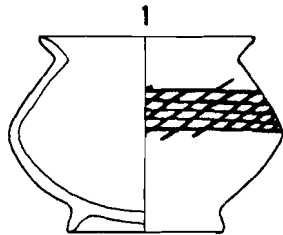

Tab. X fig. 1 R.: 1, V.: 9.4, B.: 2, fase II

Tab. X fig. 2 R.: 1, V.: 11.1, B.: 2, fase II

Tab. X fig. 3 R.: 1, V.: 9.1, B.: 2, fase I

Tab. X fig. 4 R.: 1, V.: 14.2, B.: 2, fase I

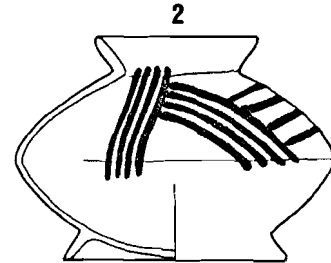

TAF X

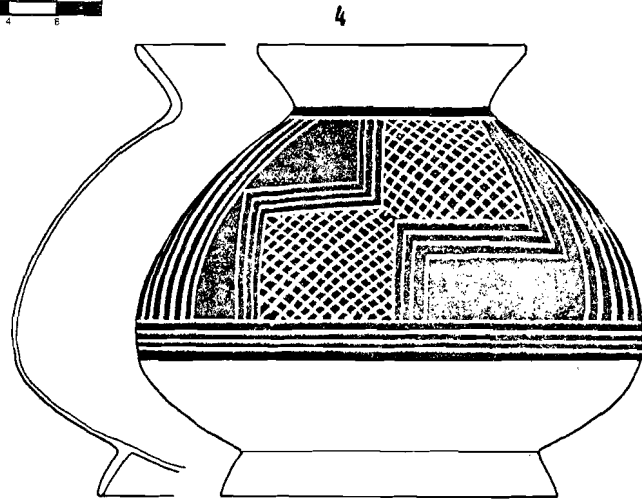
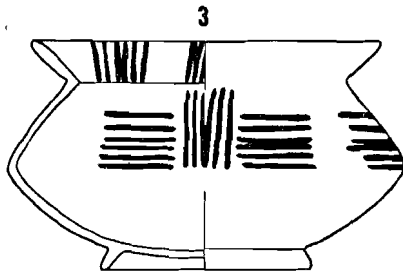
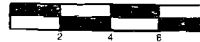

TAF. XI

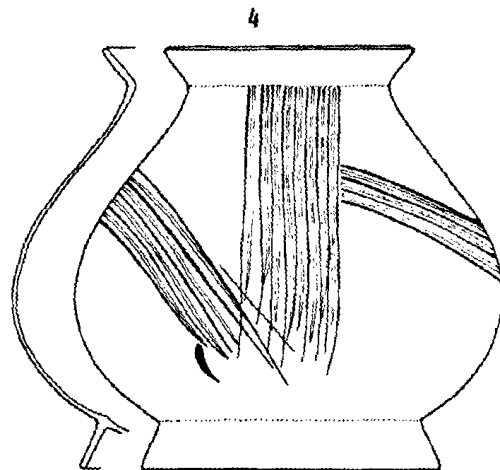
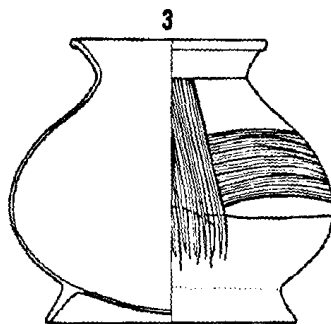
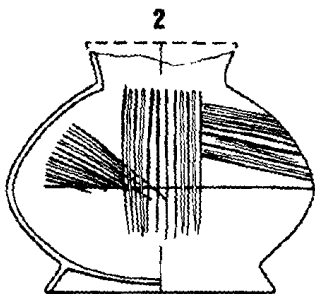
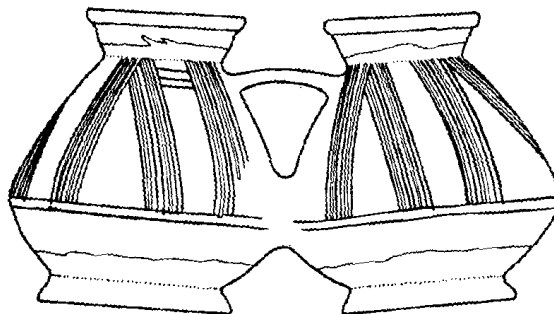
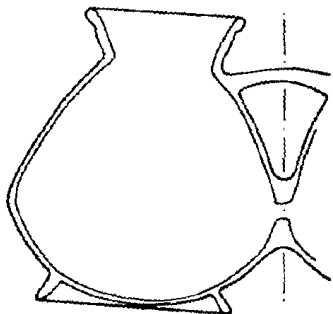
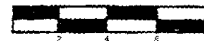

Tab. XI fig. 1-4 R.: 1, V.: 11.1, B.: 2, fase II

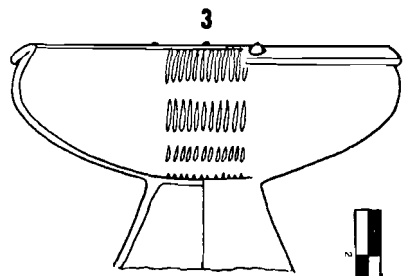
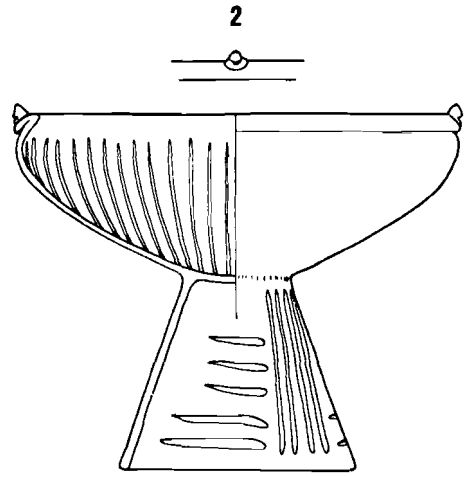
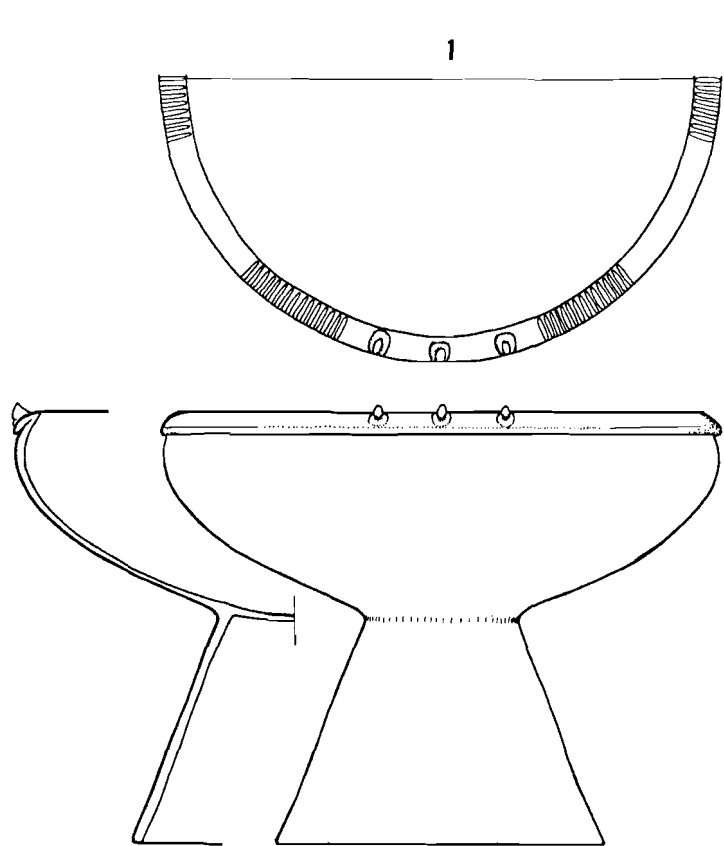

Tab. XII fig. 1-3 R.: 13, V.: 4, 5, 10.1, B.: 1, fase I

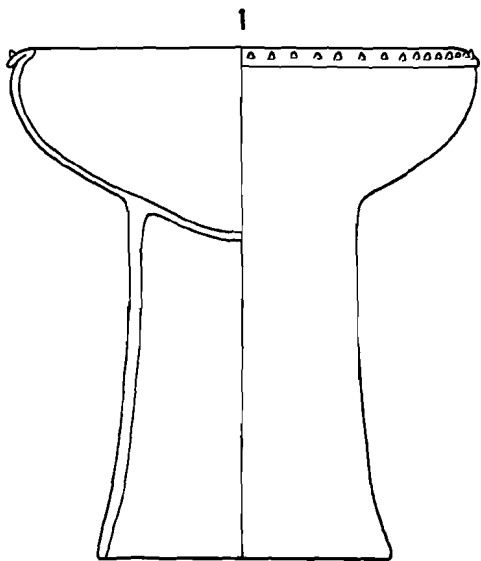

Tab. XIII fig. 1 R.: 12, V.: 7, B.: 1, fase II

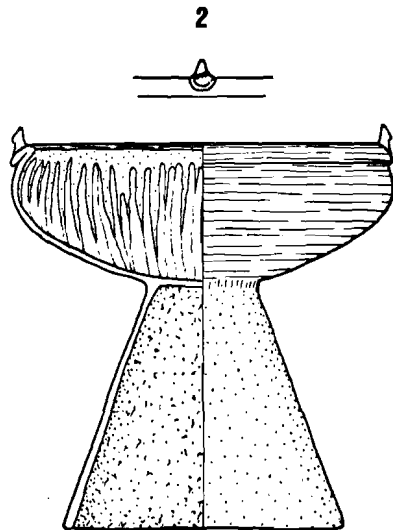

Tab. XIII fig. 2 R.: 13, V.: 4,5, B.: 1, fase I

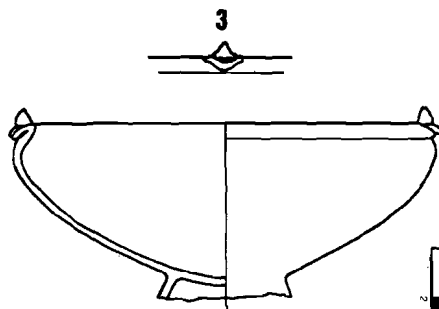

Tab. XIII fig. 3 R.: 13, V.: 5, B.: 1, fase 1



TAF XIII

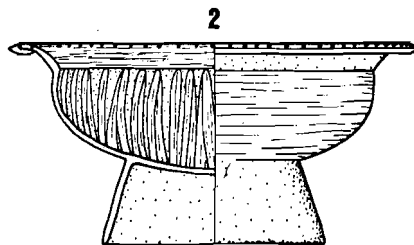
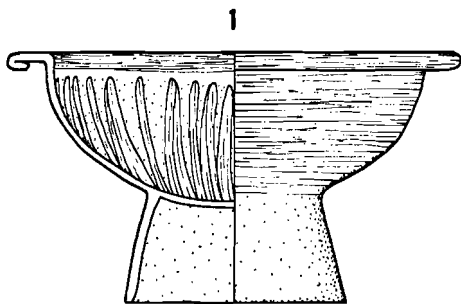

Tab. XIV fig. 1 R.: 8, V.: 4, B.: 1, fase 1

Tab. XIV fig. 2 R.: 9, V.: 1, 4, B.: 1, fase I

Tab. XIV fig. 3, 4 R.: 9, V.: 4, B.: 1. fase I

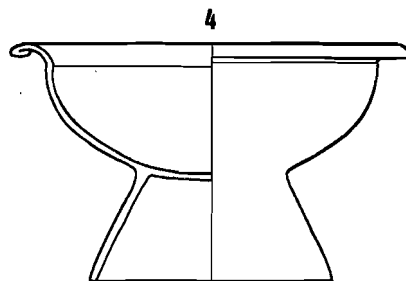
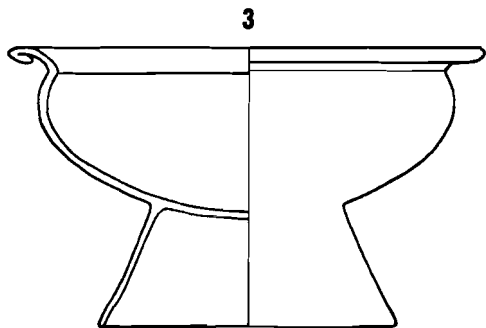

TAE XIV

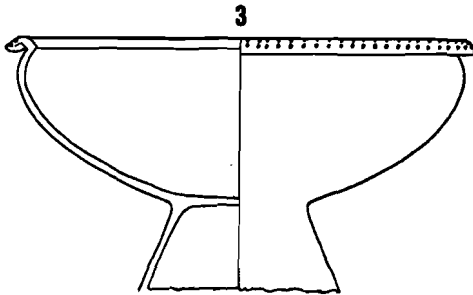
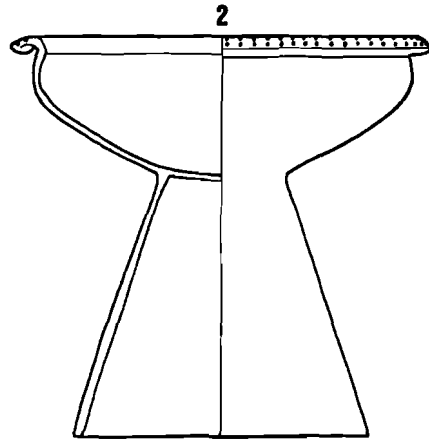
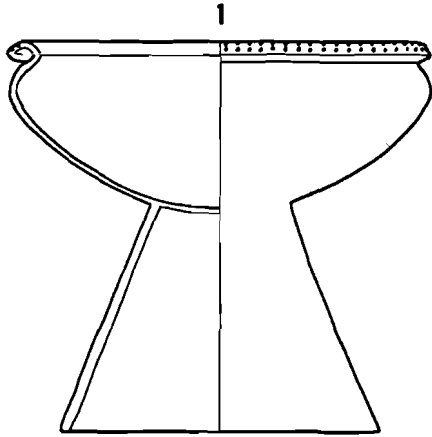

Tab. XV fig. 1-3 R.: 10, V.: 2, B.: 1, fase I



TAF. XV

TAF XVI

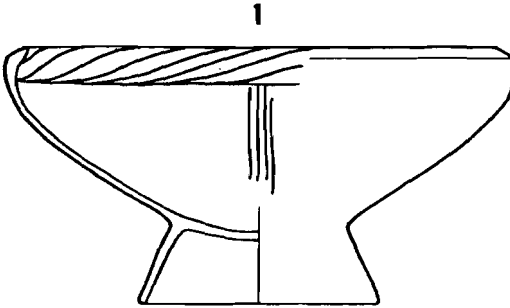

Tab. XVI fig. 1 R.: 12, V.: 9.1, B.: 1, fase 1

Tab. XVI fig. 2 R.: 12, V.: 9.1, 9.5, B.: 1, fase I

Tab. XVI fig. 3 R.: 12, V.: 9.3, B.: 1, fase II

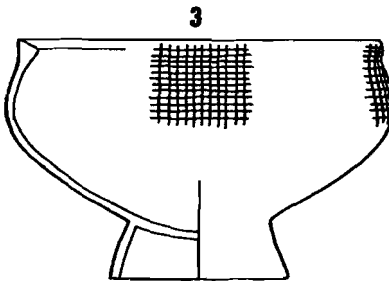
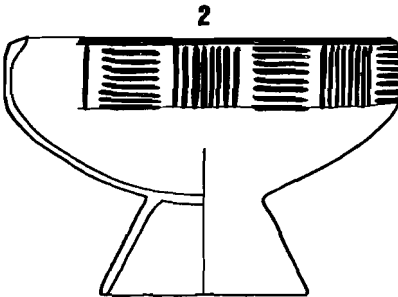

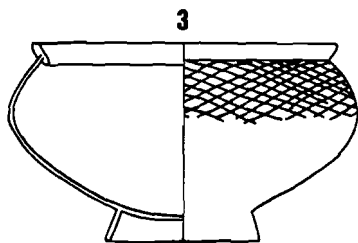
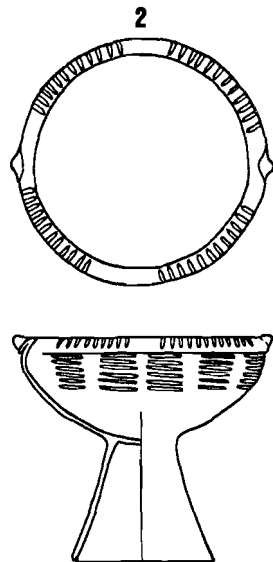
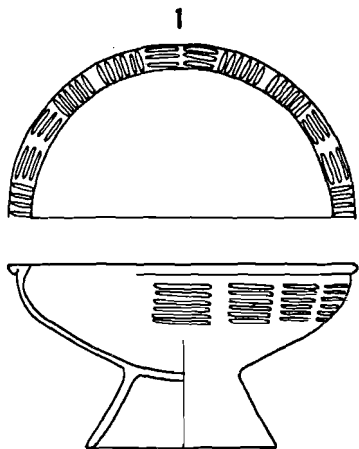

Tab. XVII fig. 1 R.: 15, V.: 10.1, B.: 1, fase I

Tab. XVII fig. 2 R.: 13, V.: 10.1, B.: 1, fase I

Tab. XVII fig. 3 R.: 1, V.: 9.4, B.: 2, fase II



TAF. XVII

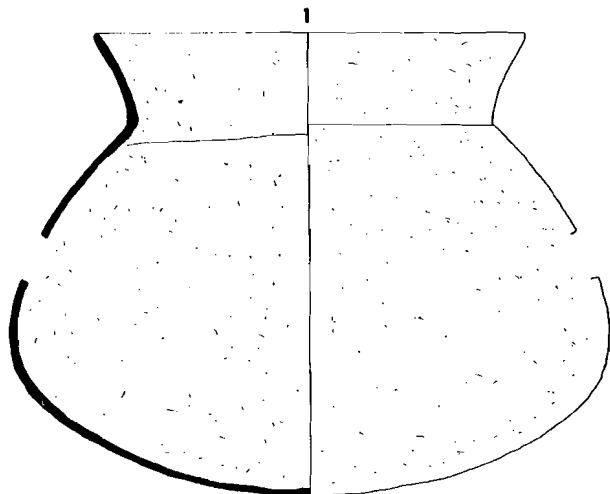

Tab. XVIII fig. 1 R.: 5, V.: 1, B.: 4, fase I

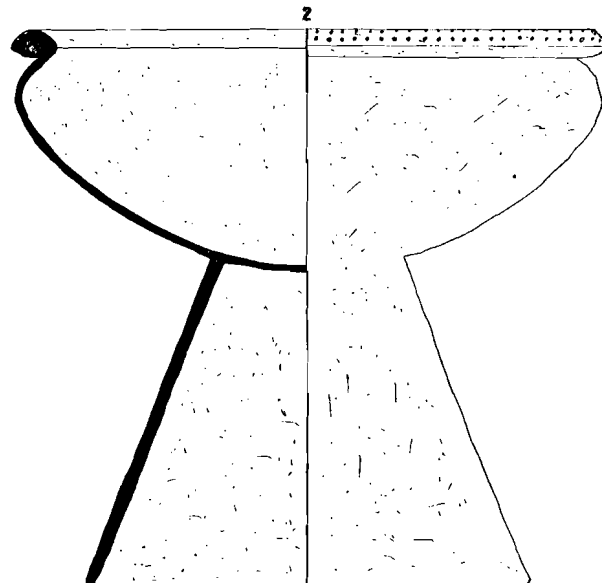

Tab. XVIII fig. 2 R.: 2, V.: 2, B.: 1, fase I

LAMINAS FOTOGRAFICAS

INDICE DE LAMINAS FOTOGRAFICAS

A. Sitios de hallazgo

tab. foto 1 fig. 1 montículo x, S 1, faja de piedra pómez sobre fosa

fig. 2 montículo x, S 4 y perfil grande visto desde S/O fosa 6

tab. foto 2 fig. 1 montículo x, S 3, molde 1–3, perfil este

fig. 2 montículo h, dif. moldes, cuadrante S/O

tab. foto 3 fig. 1 montículo n, comienzo de los trabajos

fig. 2 montículo n, nicho este

tab. foto 4 fig. 1 pueblo, S 22, perfil N/O

fig. 2 pueblo, perfil O/W 3 b, tumba 3

tab. foto 5 fig. 1 pueblo, S 8, perfil N, tumba 5

fig. 2 pirámide B, excavación de las "grachas" cerca de la rampa

tab. foto 6 fig. 1 pirámide E, moldes con piedras, plancha central

fig. 2 pirámide E, piedras, planchas central

tab. foto 7 fig. 1 pirámide G, escolanamiento de bloques de cangagua (parte sur)

fig. 2 pirámide S, muro de sustentación interno de bloques de cangagua en el barro.

tab. foto 8 fig. 1 pirámide G, molde alargado

fig. 2 pirámide H, plancha cocida y molde

B. La Cerámica

Tipo de borde: R

Tipo de decoración: V

tab. foto 9 fig. 1 tiesto de borde período I, R.: 10, V.: 2

fig. 2 tiesto de pared período I, R.: ?, V.: 3

tab. foto 10 fig. 1 tiesto de borde período I
R.: 10, V.: 5

fig. 2 tiesto de borde, período I
R.: 13, V.: 10.1

tab. foto 11 fig. 1 tiesto de borde, período I
R.: 4, V.: 10.1

fig. 2 tiesto de pared, período I
R.: ?. v.: 9.1

tab. foto 12 fig. 1 tiesto de pared, fase transitoria I/II, R.: ?, V.: 9.1

fig. 2 tiesto de pared, fase transitoria I/II, R.: ?, V.: 9.2

- tab. foto 13 fig. 1 tiesto de pared, período II
R.: ?, V.: 11.1
- fig. 2 tiesto de borde, período II
R.: 11, V.: 9.4
- tab. foto 14 fig. 1 tiesto de borde, período II
R.: 12, V.: 7 + 10.2
- fig. 2 tiesto de borde, período II
R.: 12, V.: 9.4 + 10.2
- tab. foto 15 fig. 1 tiesto de borde, período II
R.: 12, V.: 10.3
- fig. 2 tiesto de pared, período II
R.: ?, V.: 11.6

C. Figurinas

- tab. foto 16 fig. 1 figurina (sólida), tipo 1.3.1, I período I
- fig. 2 figurina (sólida), tipo 1.3.1, III, período I
- tab. foto 17 fig. 1 figurina (sólida), tipo 1.3.1, IV período I
- fig. 2 figurina (sólida), tipo 1.31, V período I
- tab. foto 18 fig. 1 figurina (sólida), tipo 1.3.1, VI, período II
- fig. 2 figurina (hueca), tipo 1.3.2, I, período II

D. Fragmentos de vasijas antropo-/zoomorfas

- tab. foto 19 fig. 1 fragmento zoomorfo

tipo 1.3.4/e, período II

fig. 2 fragmento, brazo, mano y pecho aplicados plásticamente
tipo 1.3.3/II, período II

E. Modelo

tab. foto 20 fig. 1 mitad de un modelo ovalado punteagudo, motivo de la vasija: cabeza de pájaro, período II

F. Artefactos de hueso

tab. foto 21 fig. 1 espátula, período I

fig. 2 espátula, período II

tab. foto 22 fig. 1 silbato, período I

fig. 2 silbato, período II

tab. foto 23 fig. 1 punta de hueso, período I

fig. 2 herramienta con función de cortar, rayar, período II

tab. foto 24 fig. 1 perforador, período I

fig. 2 perforados, período I

tab. foto 25 fig. 1 rasgos de cepillar

fig. 2 rasgos de golpear

tab. foto 26 fig. 1 perforación rápida

fig. 2 perforación irregular

G. Metal de la época española

tab. foto 27 fig. 1 aguja de bronce (del tiempo colonial?)

fig. 2 aguja de bronce con motivo de gallo (del tiempo colonial ?)

A. Sitios de hallazgo

Lam. I

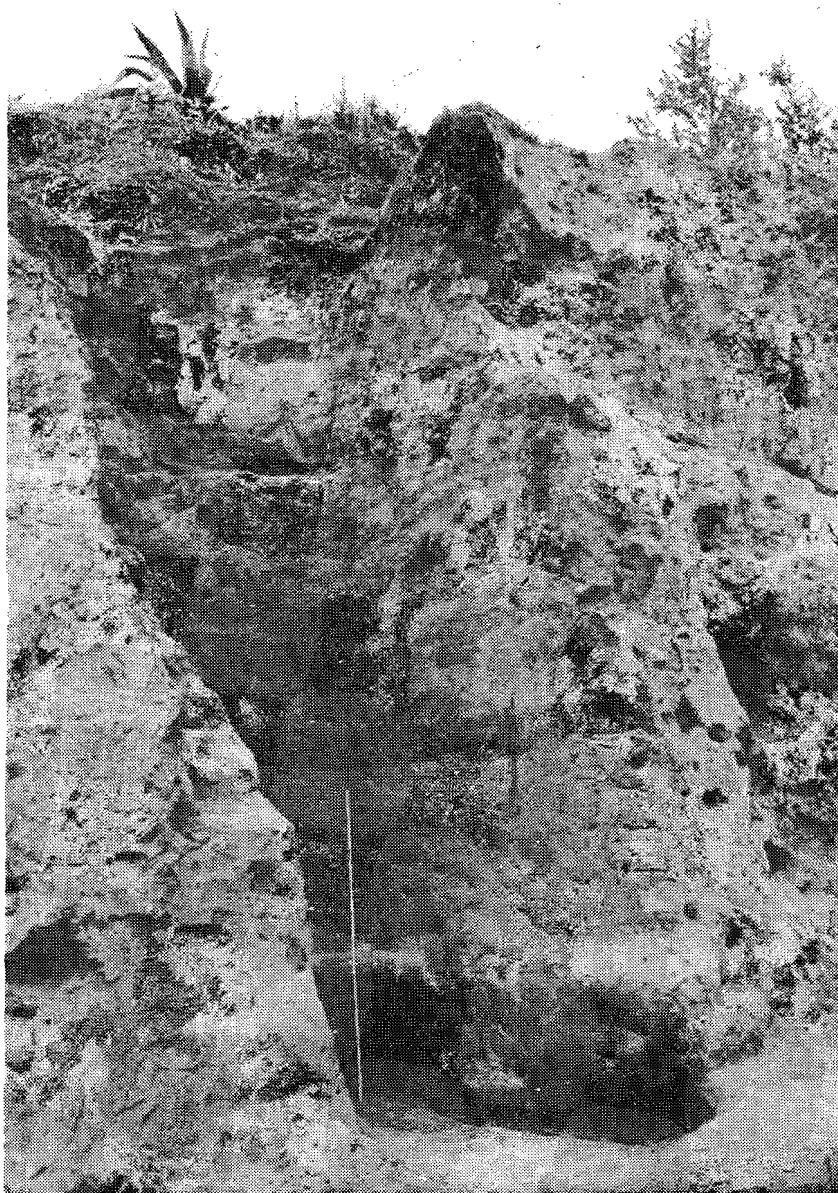

fig. 1 montículo x S 1, faja de piedra pómez sobre fosa

Lam. I

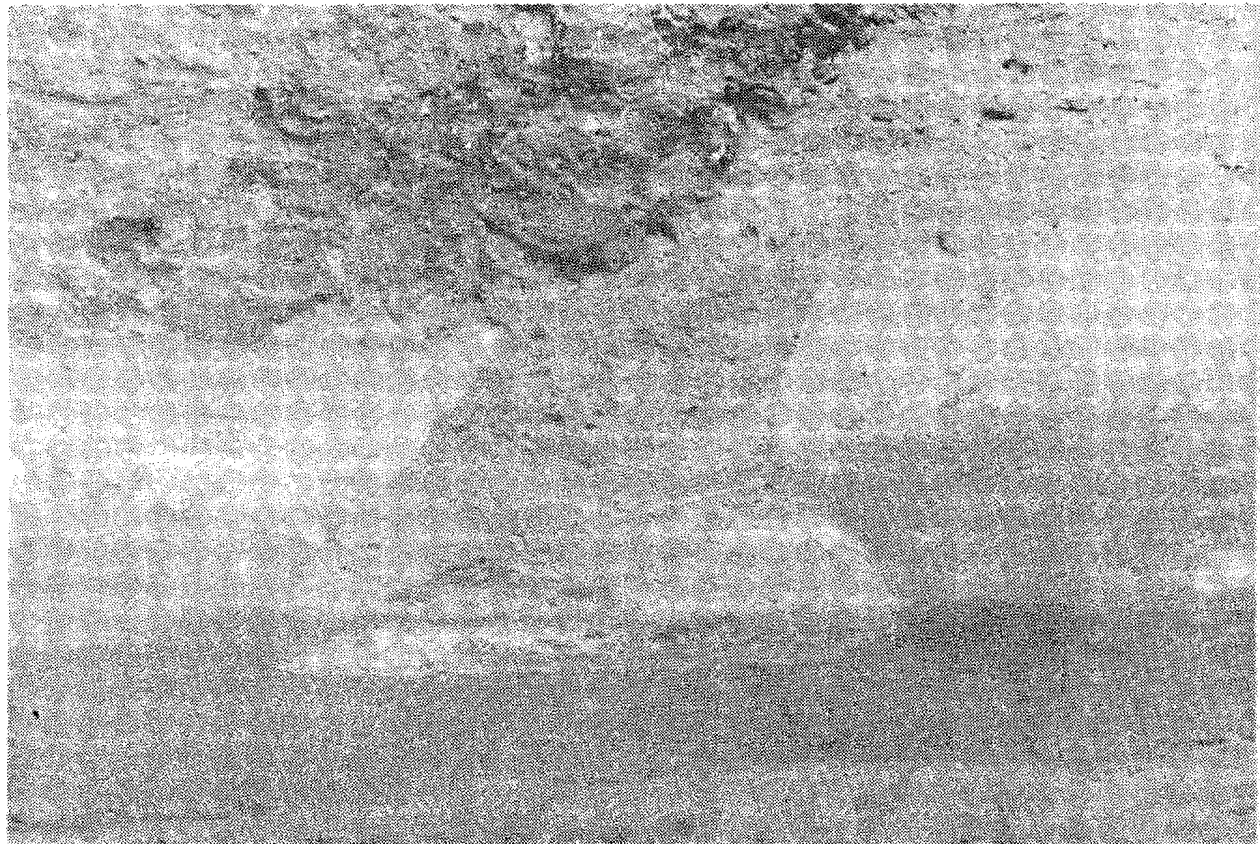
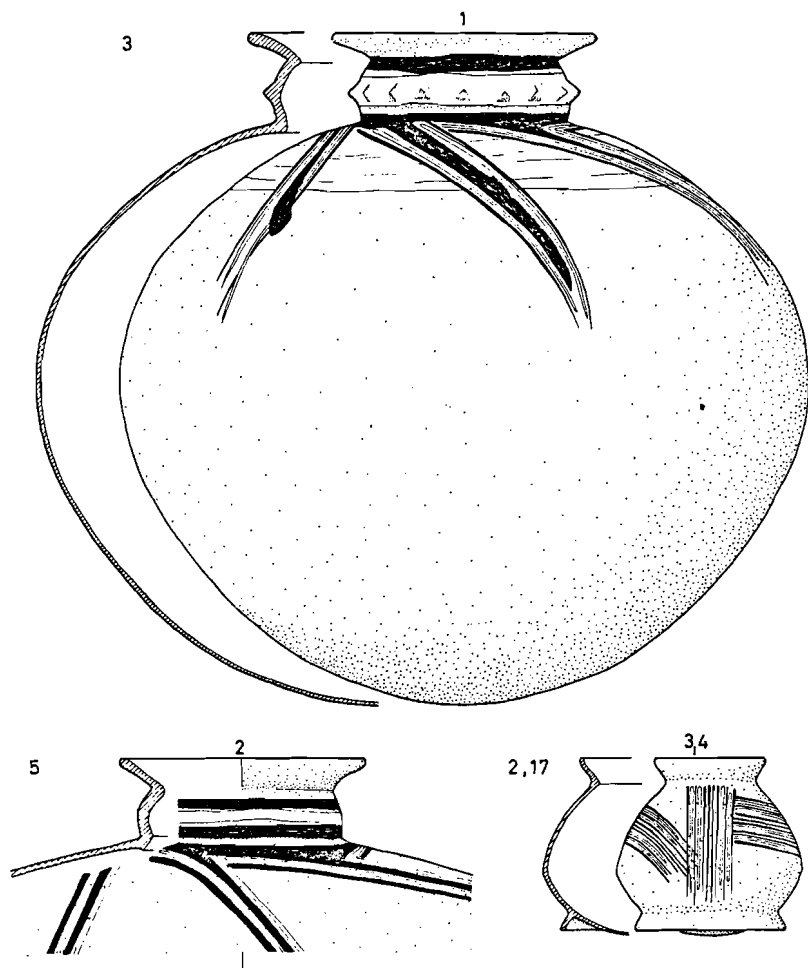

fig. 2 montículo x S 4 y perfil grande visto dese S/O, fosa 6

Tab XIX-XXIV Hallazgos cerrados (descripción véase el capítulo IV, 1.17, pág. 144-158)



Tab. XIX fig. 1-3 (vasijas 2, 3, 5, 17) montículo n, fase I/II

TAF XX

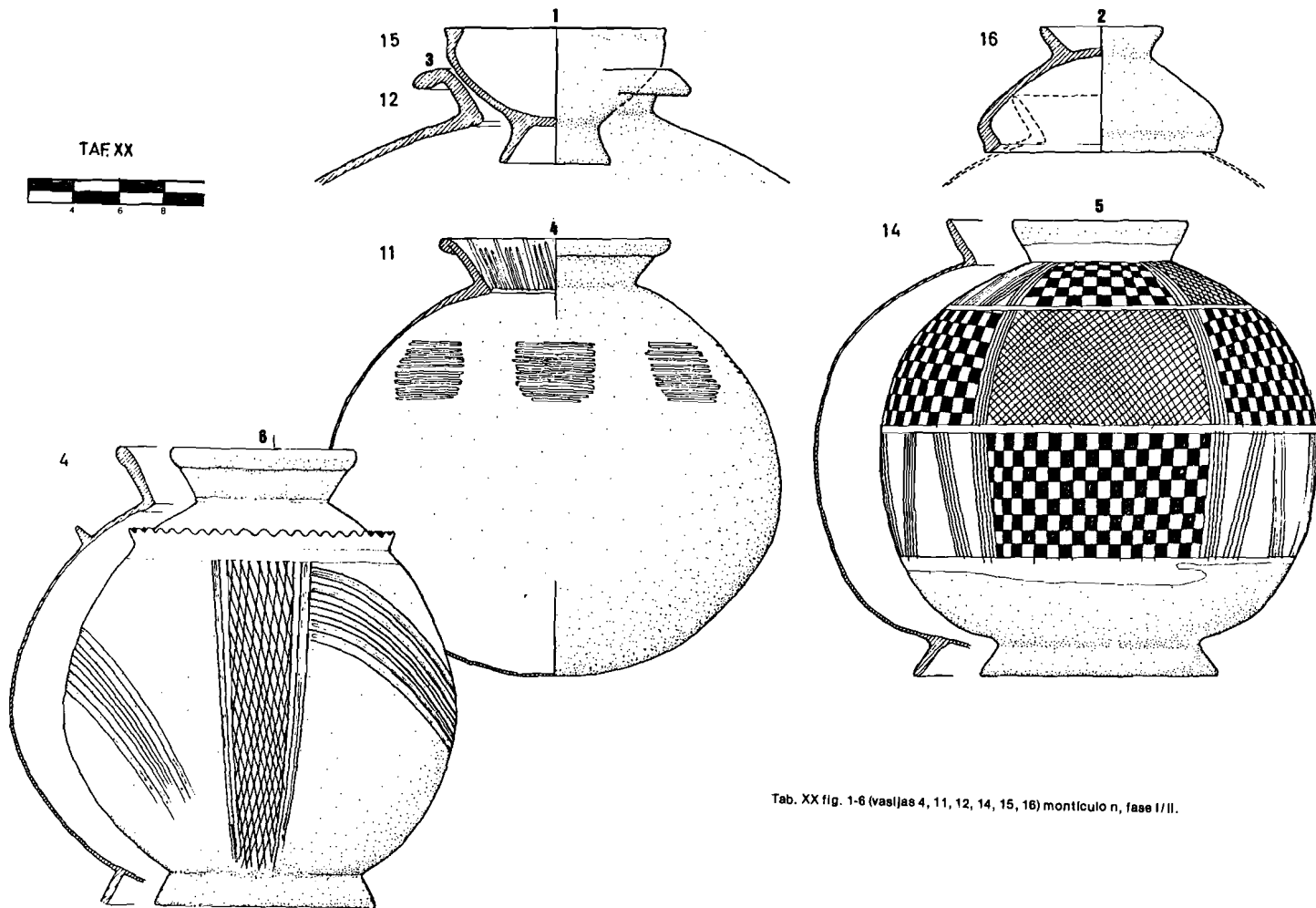

Tab. XX fig. 1-6 (vasijas 4, 11, 12, 14, 15, 16) montículo n, fase I/II.

TAF XXI

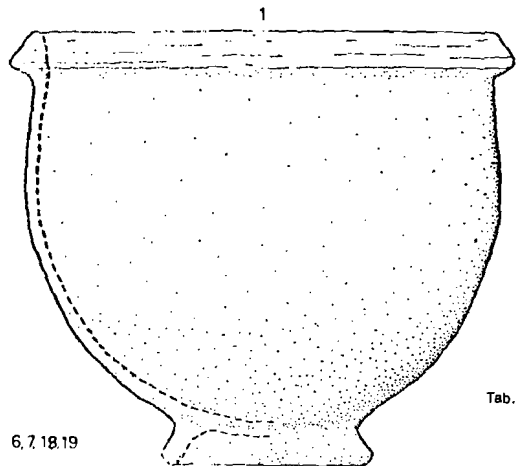

6, 7, 18, 19

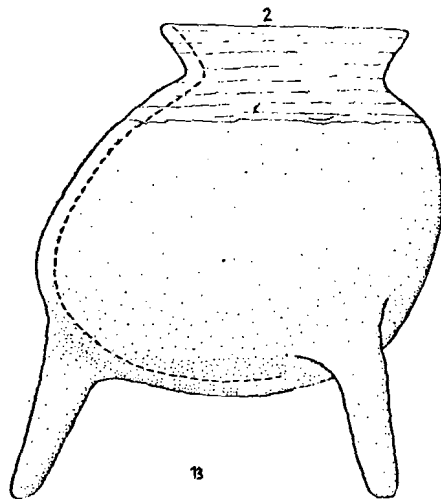

13

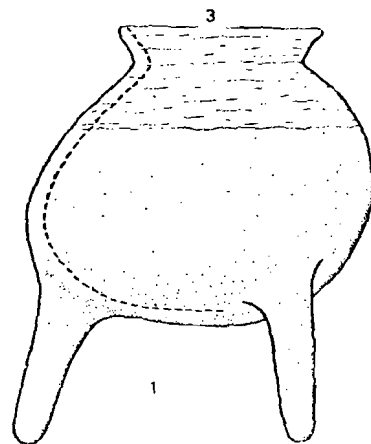

1

Tab. XXI Fig. 1-3 (vasijas 1, 6, 7, 13, 18, 19) montículo n. fase I/II

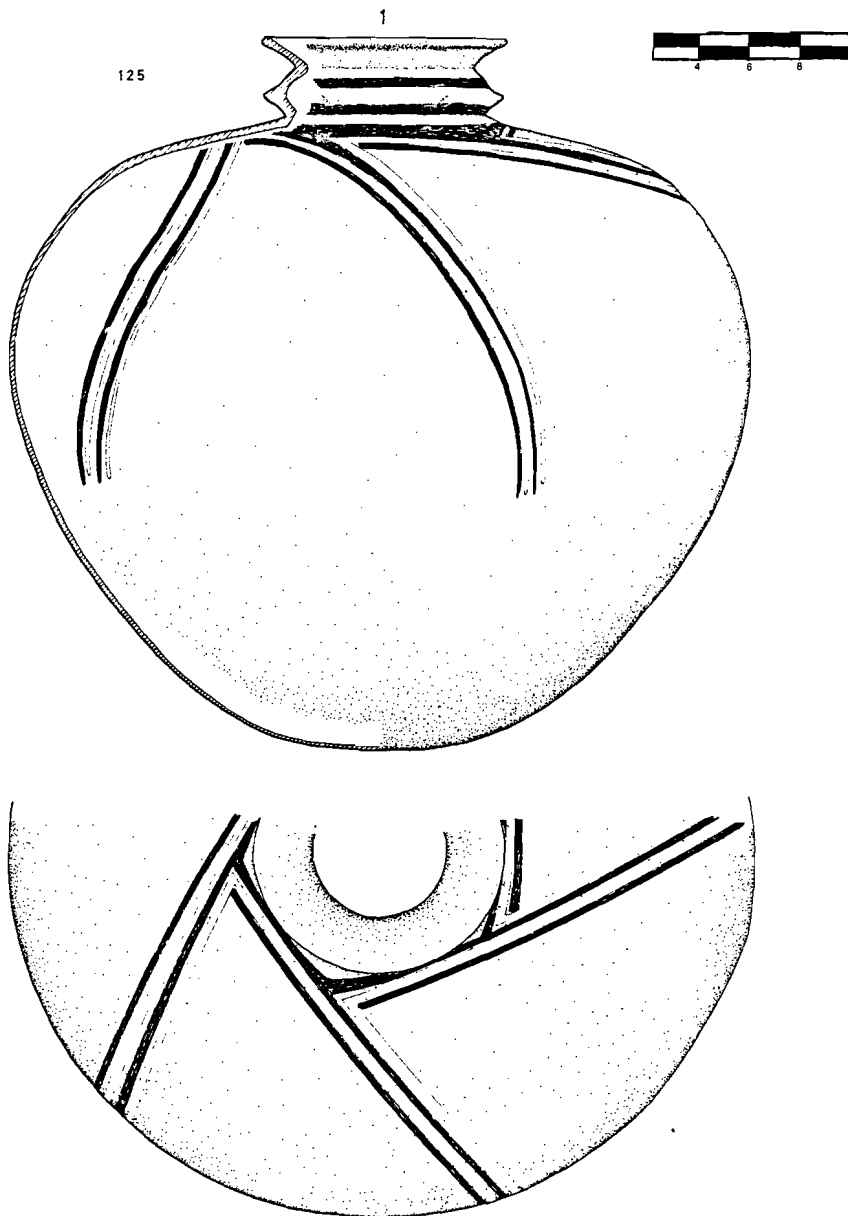

Tab. XXII fig. 1 monticulo a, fase I/II

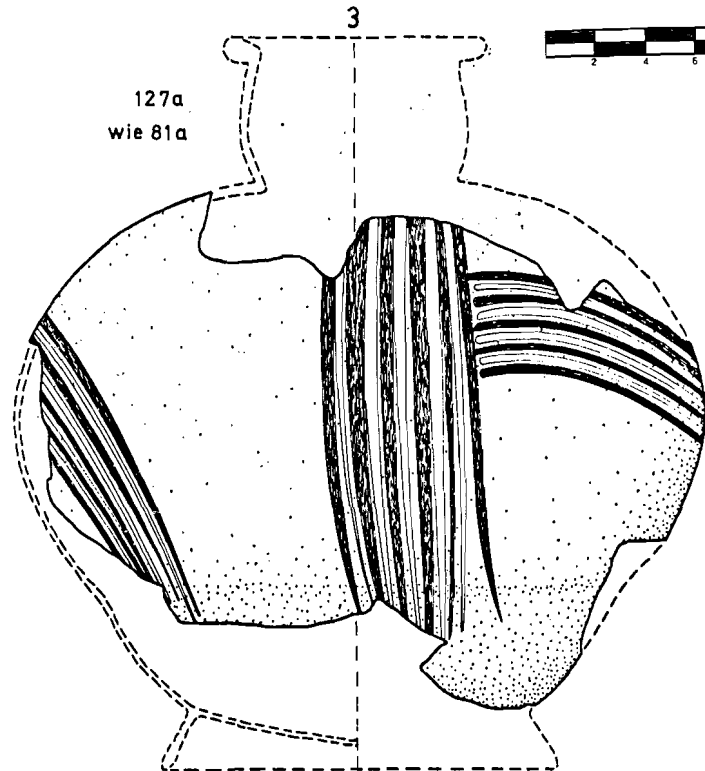
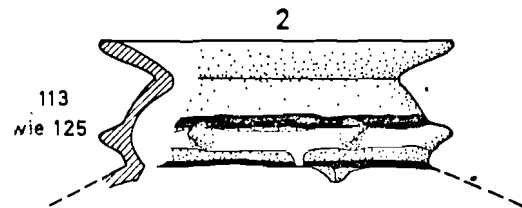
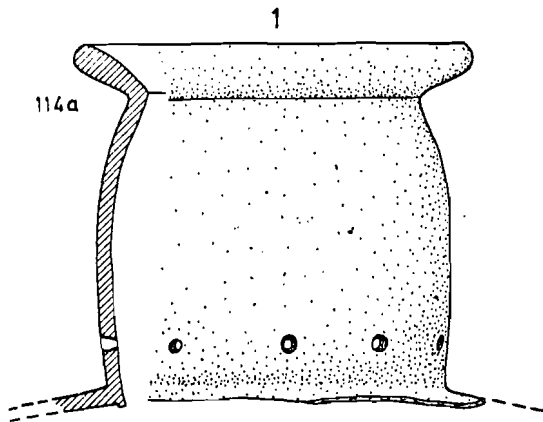

Tab. XXIII fig. 1-3 monticulo a, fase I/II

TAF XXIV



Tab. XXIV fig. 4-6 pueblo, corte 8, tumba 5, fase I o II/II?

Tab. XXIV fig. 4-6 montículo m, fase I/II o II (?)

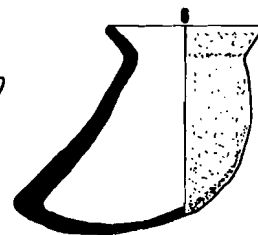
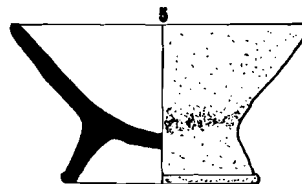
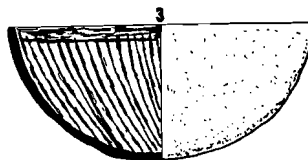
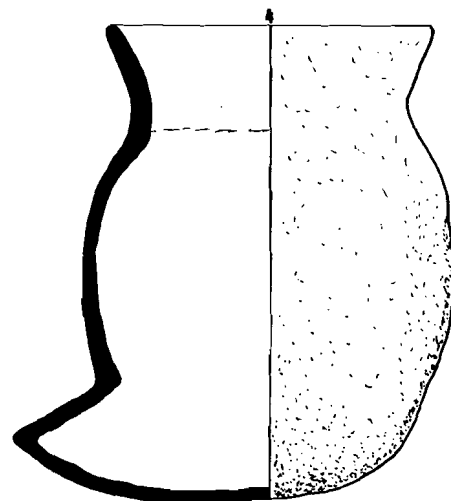
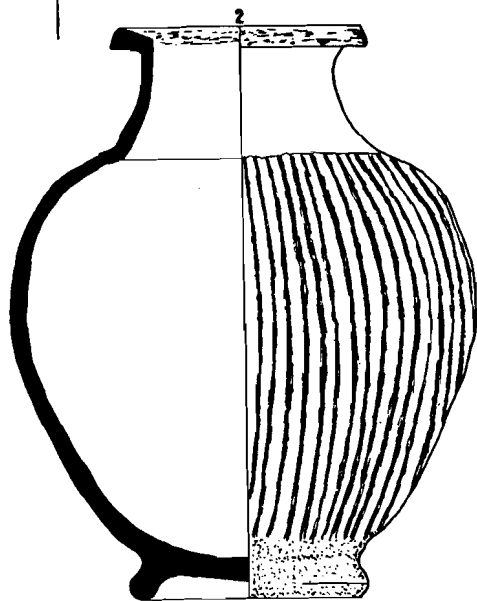
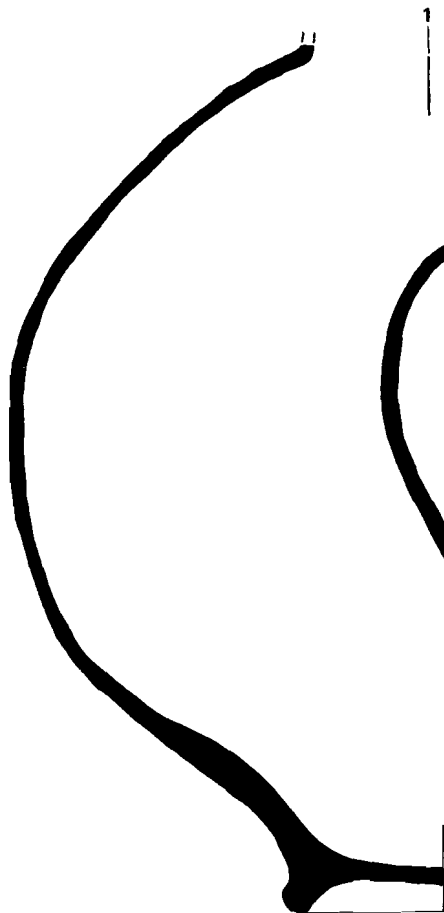

Tab. XXV - XXVII 1. comparación cerámica fina-tosca; 2. cerámica foránea (tuza, inca)

TAF XXV

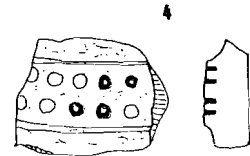
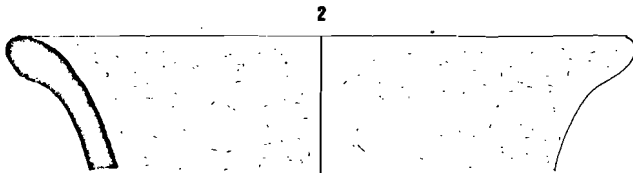
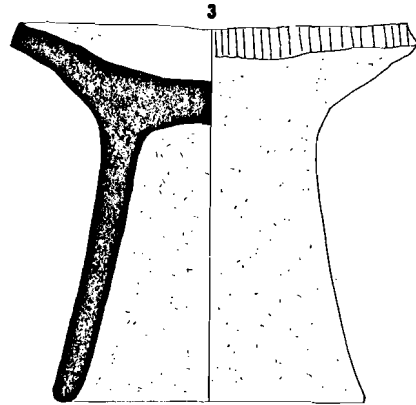
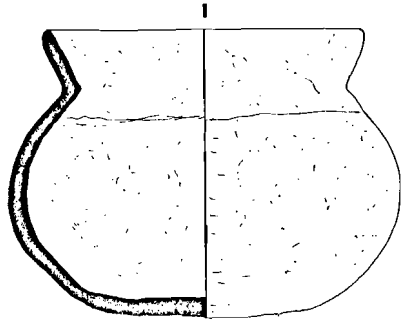

Tab. XXV fig. 1-4 cerámica tosca, fase I

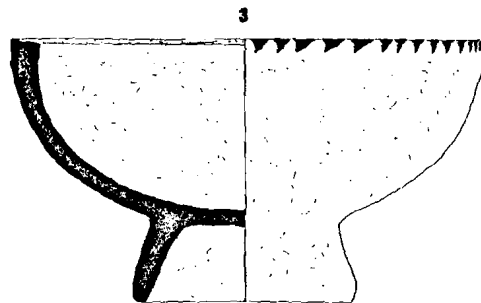
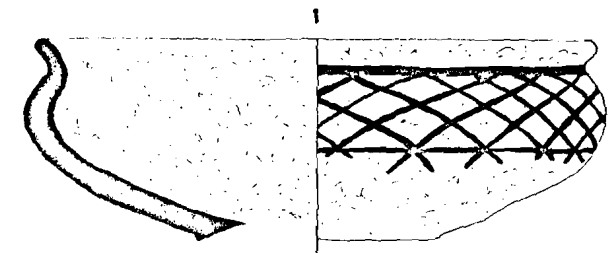

TAF XXVI

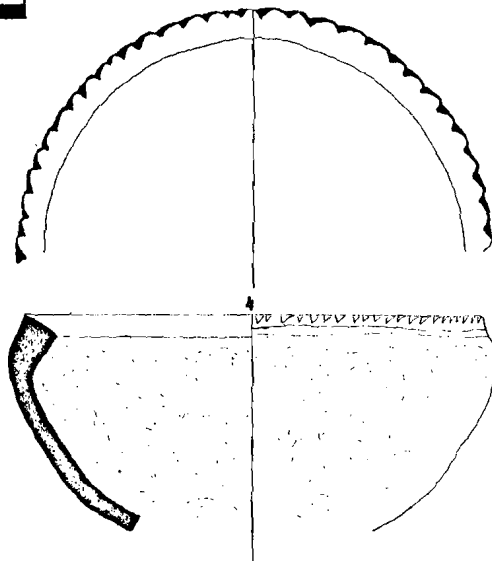
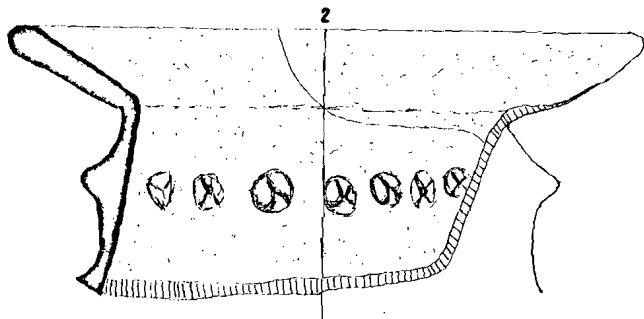

Tab. XXVI fig. 1-4 cerámica tosca, fase II

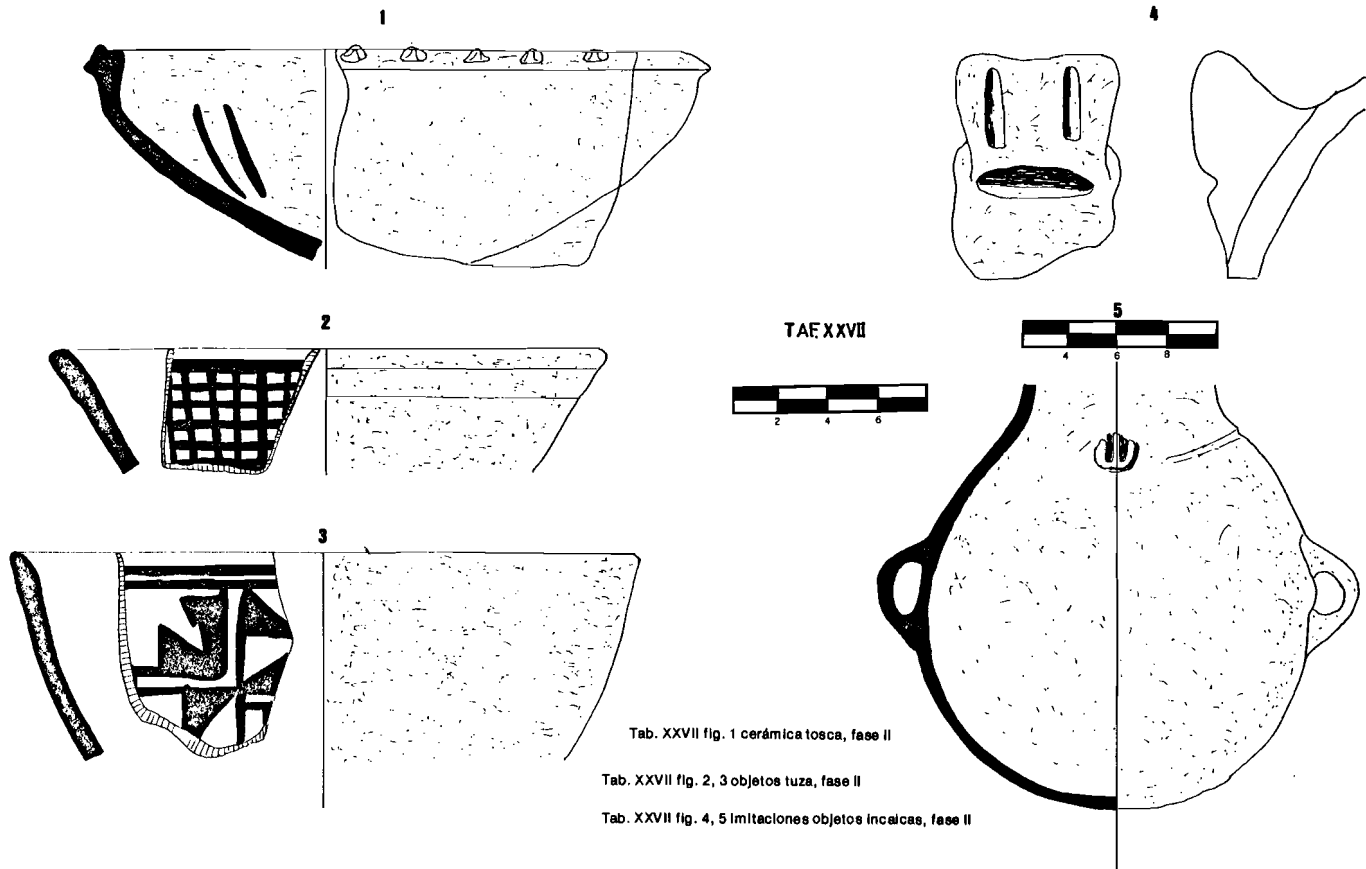

Tab. XXVII fig. 1 cerámica tosca, fase II

Tab. XXVII fig. 2, 3 objetos tuza, fase II

Tab. XXVII fig. 4, 5 imitaciones objetos incaicas, fase II

Tab. XXVIII - XXXII figurinas, vasijas antropo-/zoomorfas o aplicaciones de vasijas, silbatos, pendientes, modelos (arcilla), discos cerámicos, (descripción véase cap. IV, 1.3-1.5)

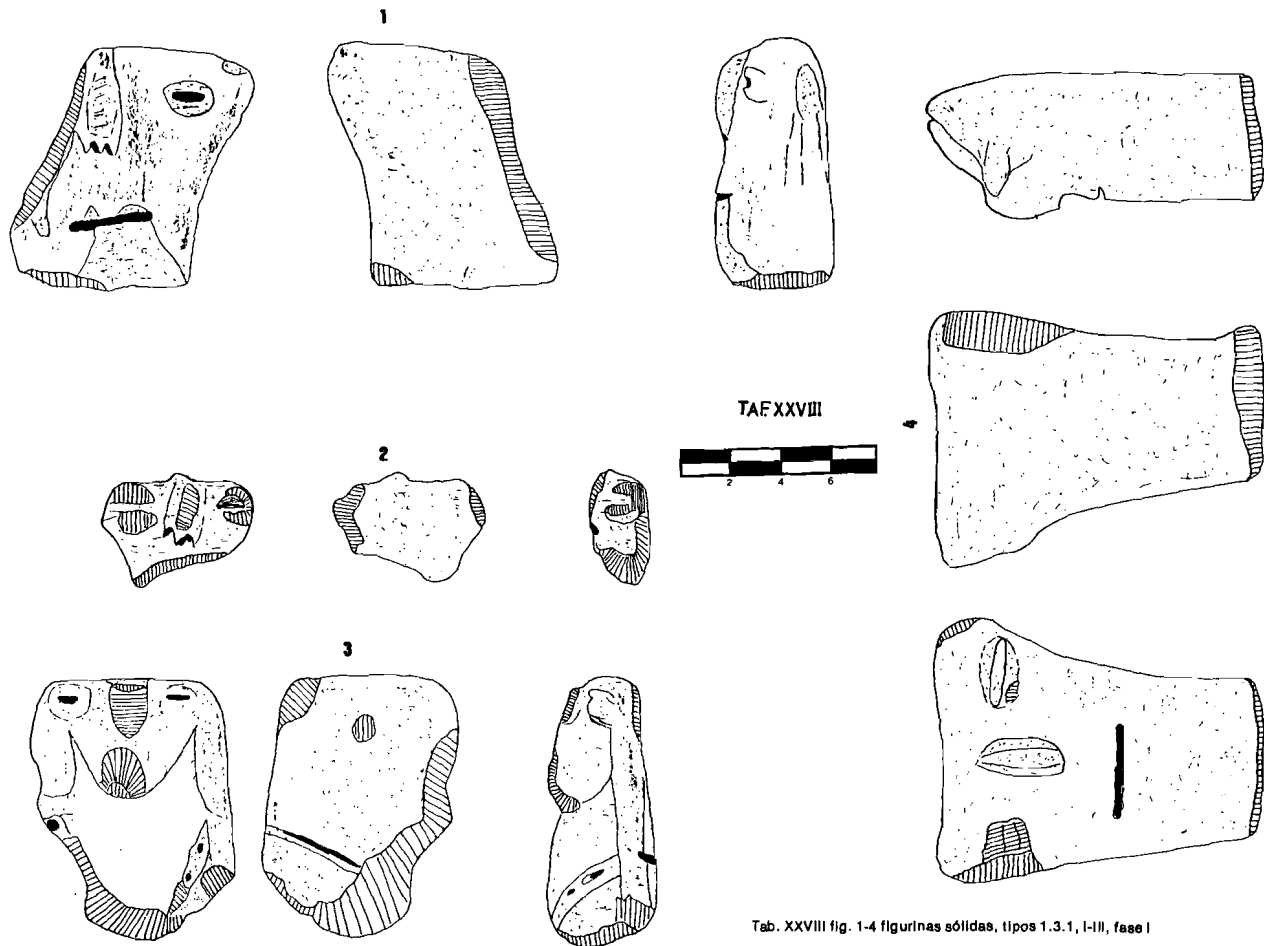

Tab. XXVIII fig. 1-4 figurinas sólidas, tipos 1.3.1, I-II, fase I

Tab. XXIX fig. 1-3 figurinas sólidas, tipos 1.3.1, IV-VI, fase I/II, II

Tab. XXIX fig. 4, 5 figuras huecas, tipos 1.3.2, I + II, fase II

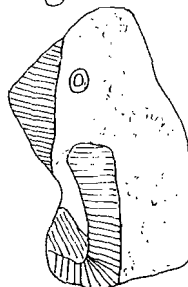
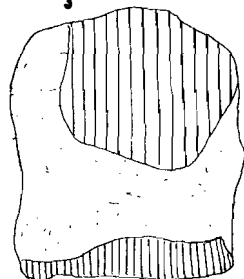
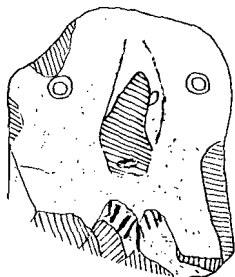
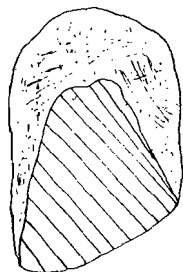
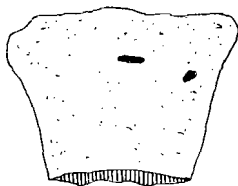
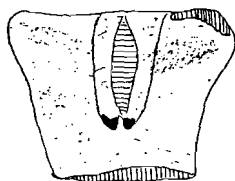

TAF XXIX



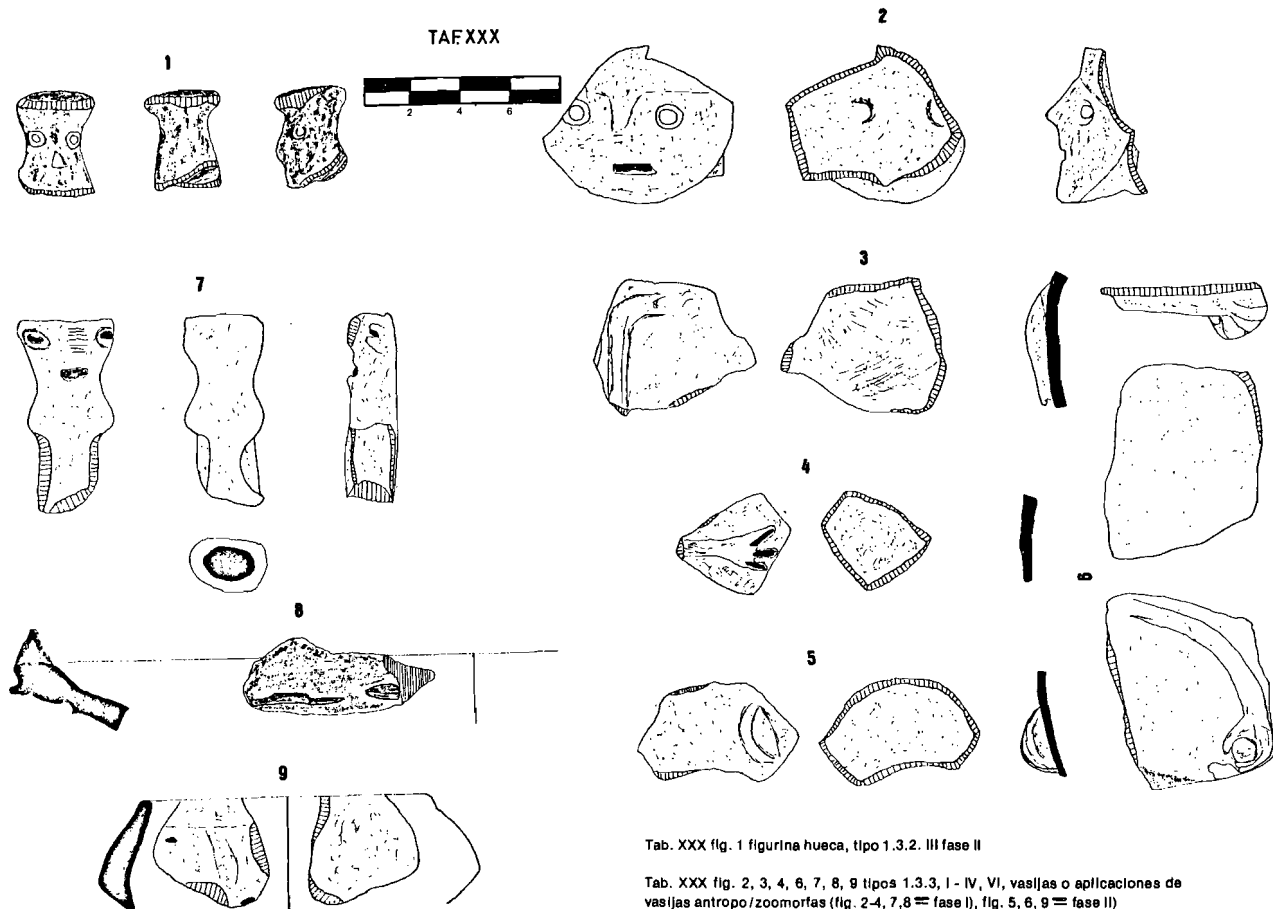

Tab. XXX fig. 1 figurina hueca, tipo 1.3.2. III fase II

Tab. XXX fig. 2, 3, 4, 6, 7, 8, 9 tipos 1.3.3. I - IV, VI, vasijas o aplicaciones de vasijas antrozo/zoomortas (fig. 2-4, 7, 8 = fase I), fig. 5, 6, 9 = fase II)

Tab. XXXI fig. 1 fragmento de pie sólido antropomorfo (?), tipo 1.3.3, V, fase II

Tab. XXXI fig. 2-8 otros, 1.3.4, a, b, e, (fig. 3, 4 = fase I, fig. 2, 5 = 8 — fase II)

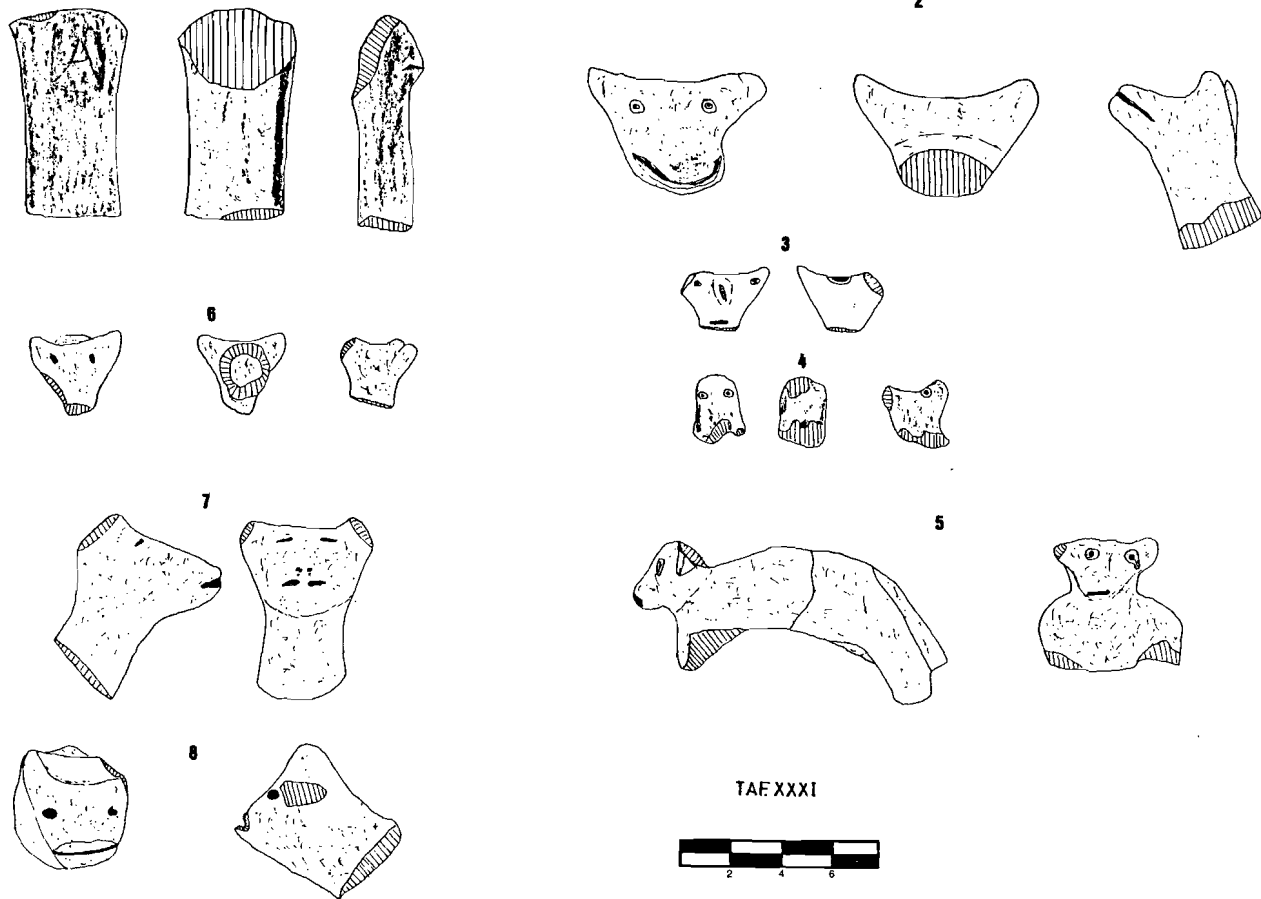

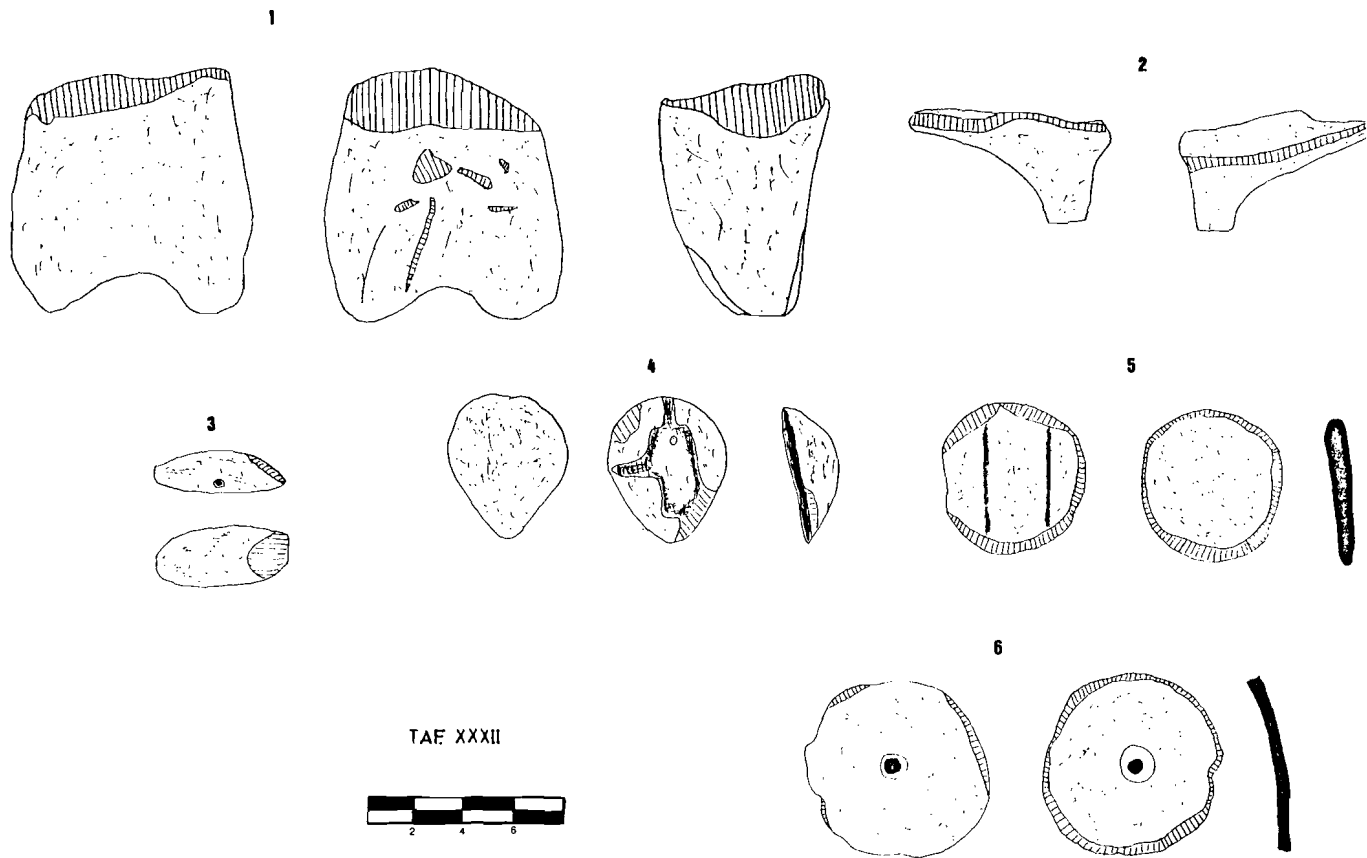

Tab. XXXII fig. 1-3 otros 1.3.4 c, d, f (fig. 2, fase I, fig. 1, 3 = fase II)

Tab. XXXII fig. 4 modelo, fase II

Tab. XXXII fig. 5, 6 discos cerámicos, fase I - II

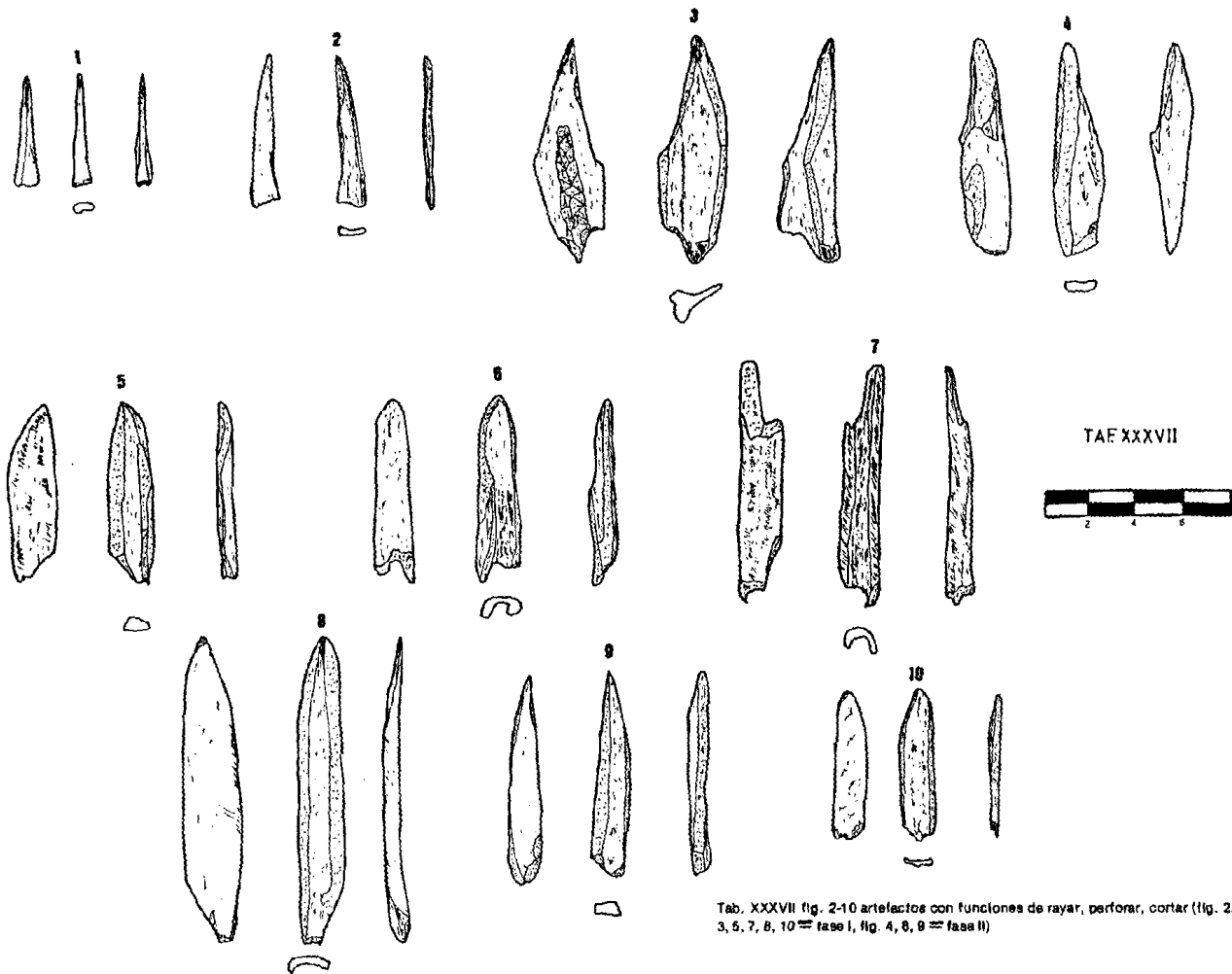

Tab. XXXVII fig. 2-10 artefactos con funciones de rayar, perforar, cortar (fig. 2, 3, 5, 7, 8, 10 = fase I, fig. 4, 6, 9 = fase II)

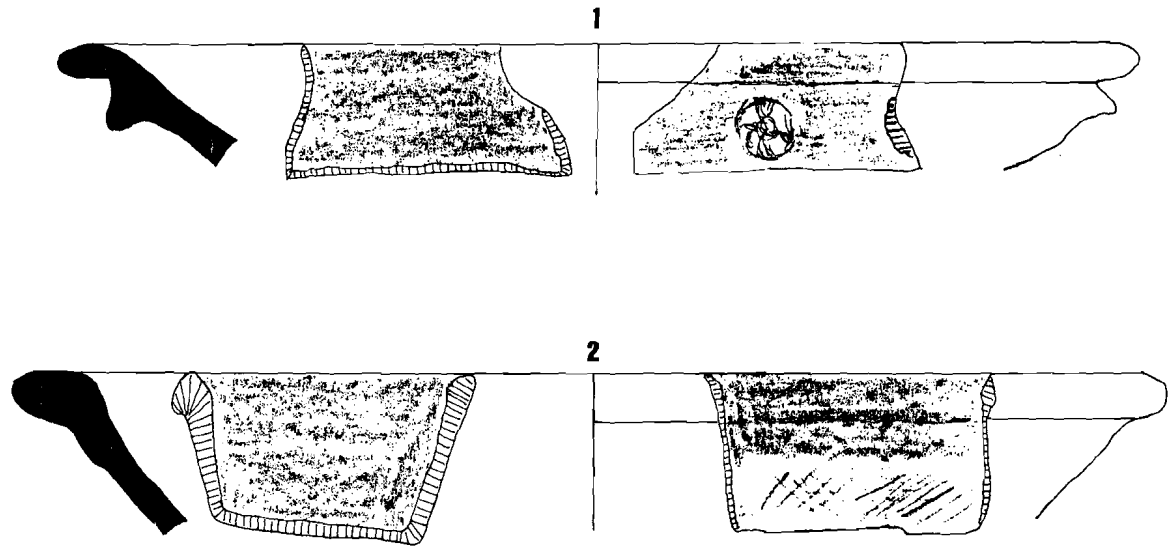

Tab. XXXVIII fig. 1,2 "Comoteras con wavy rim profile" (Comoteras con pie y labio ondulado) fase I



TAF XXXVIII

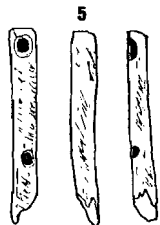
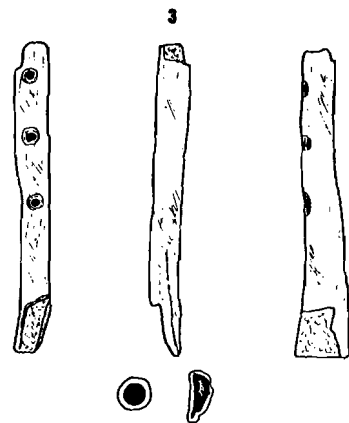
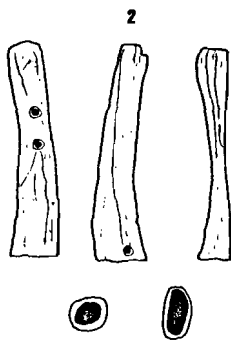
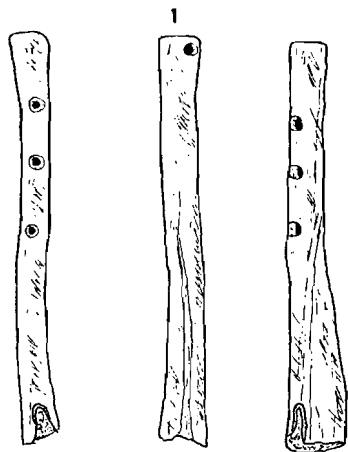

TAF XXXV

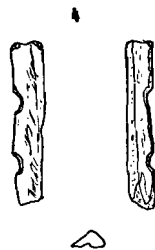

Tab. XXXV fig. 1-7 puntas de hueso (fig. 1-6 = fase I, fig. 7 = fase II)

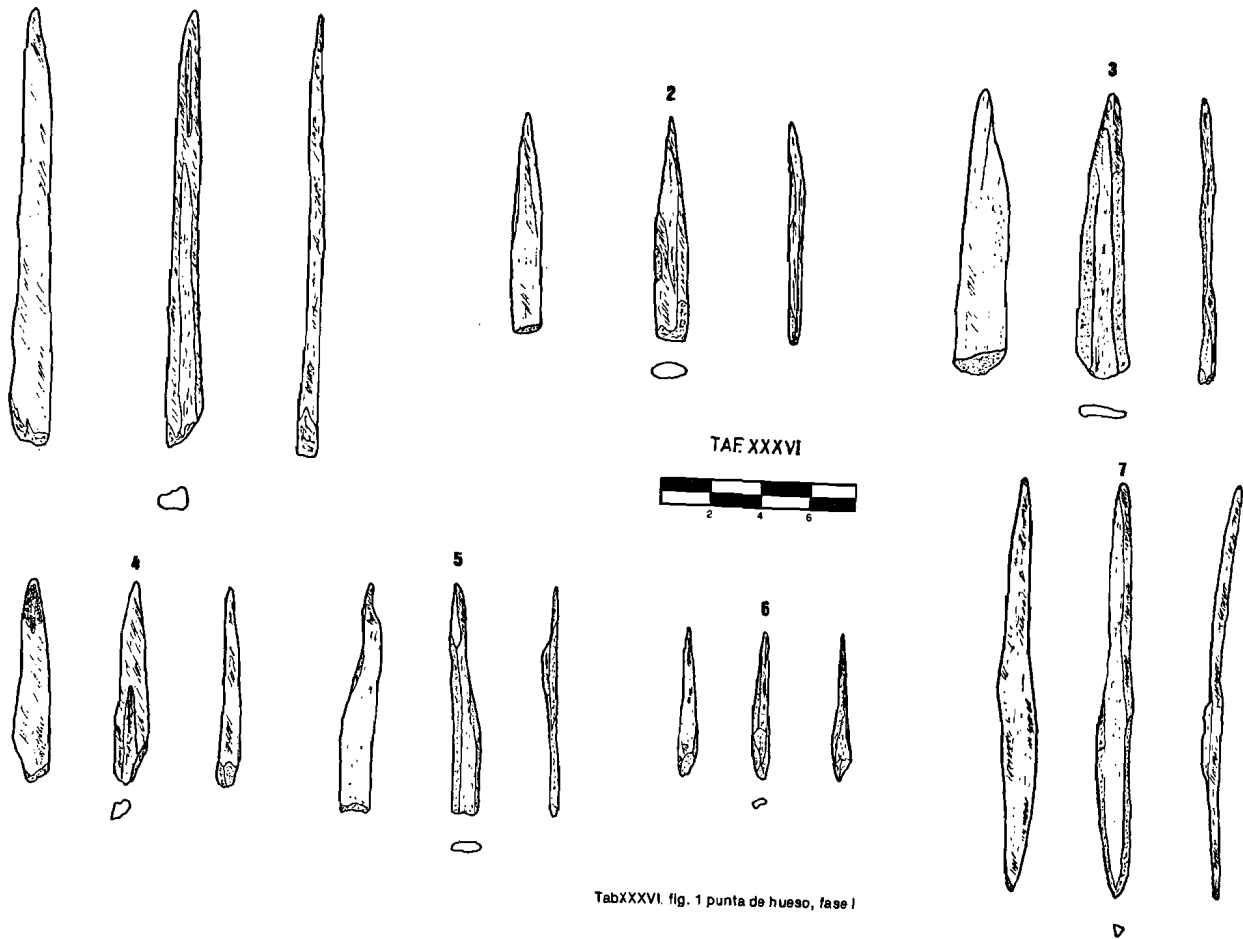

TabXXXVI. fig. 1 punta de hueso, fase I

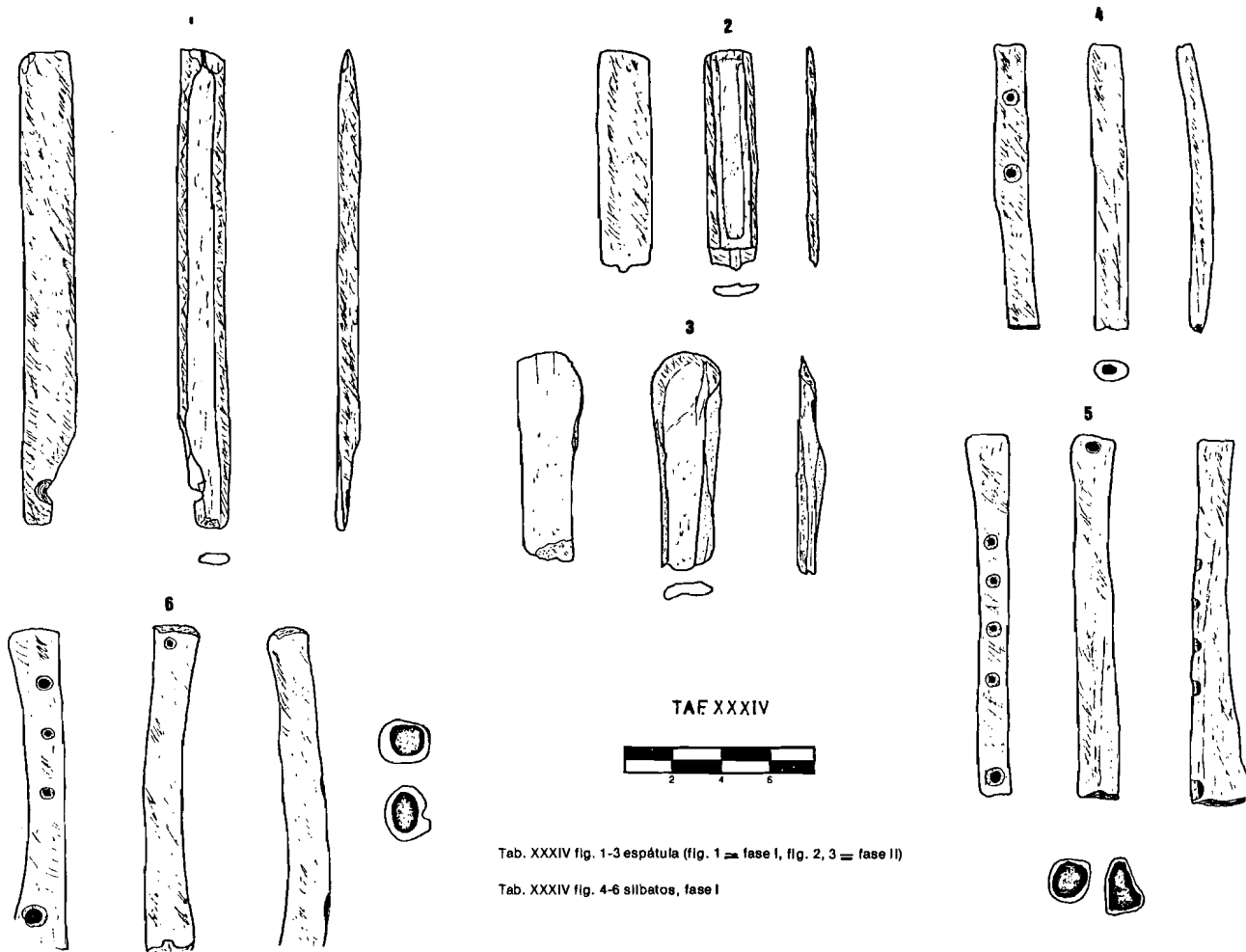

Tab. XXXIV fig. 1-3 espátula (fig. 1 = fase I, fig. 2, 3 = fase II)

Tab. XXXIV fig. 4-6 silbatos, fase I

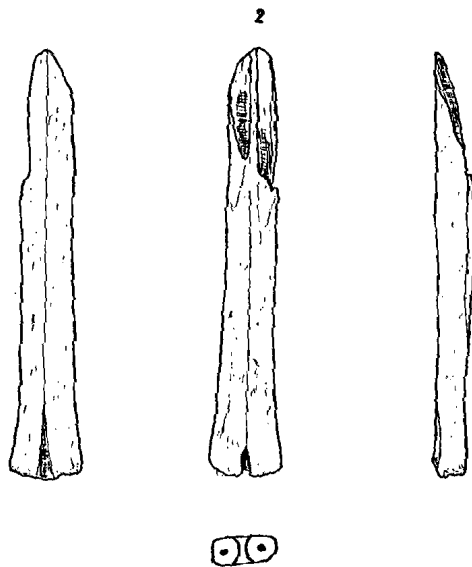
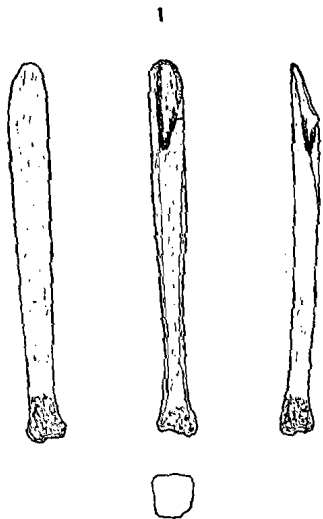

TAF XXXIII

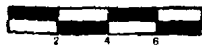

Tab. XXXIII fig. 1-4 espátula, fase I

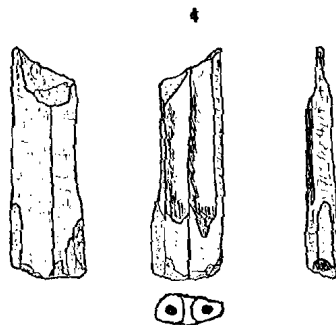
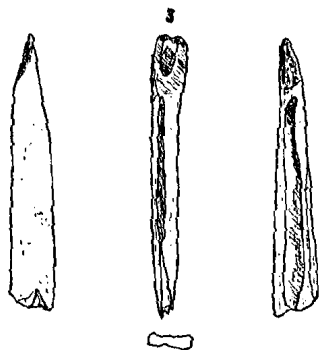

Tab. XXXIII - XXXVII artefactos de hueso

Lam. II

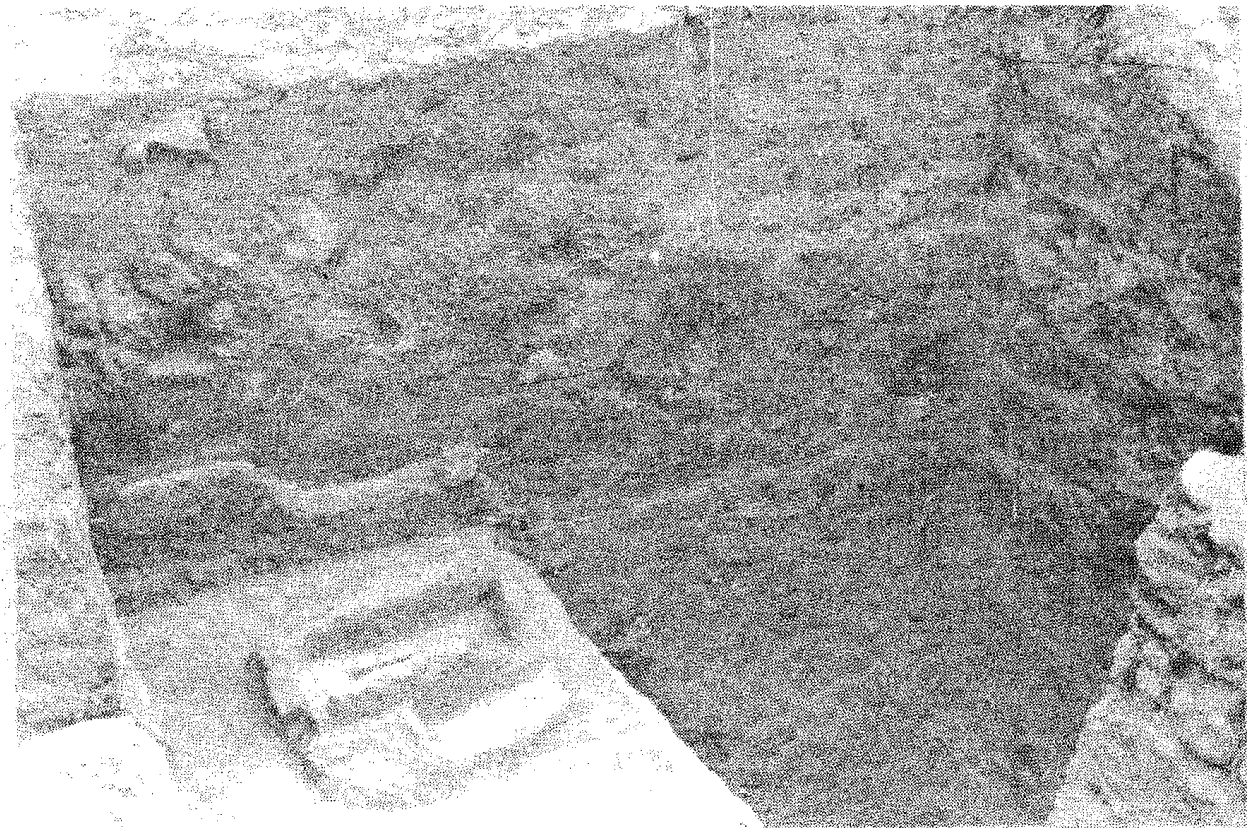

fig. 1 montículo x, S 3, molde 1 — 3, perfil este



fig. 2 montículo h, dif. moldes, cuadrante S/O

Lam. III



fig. 1 montículo n, comienzo de los trabajos

Lam. III

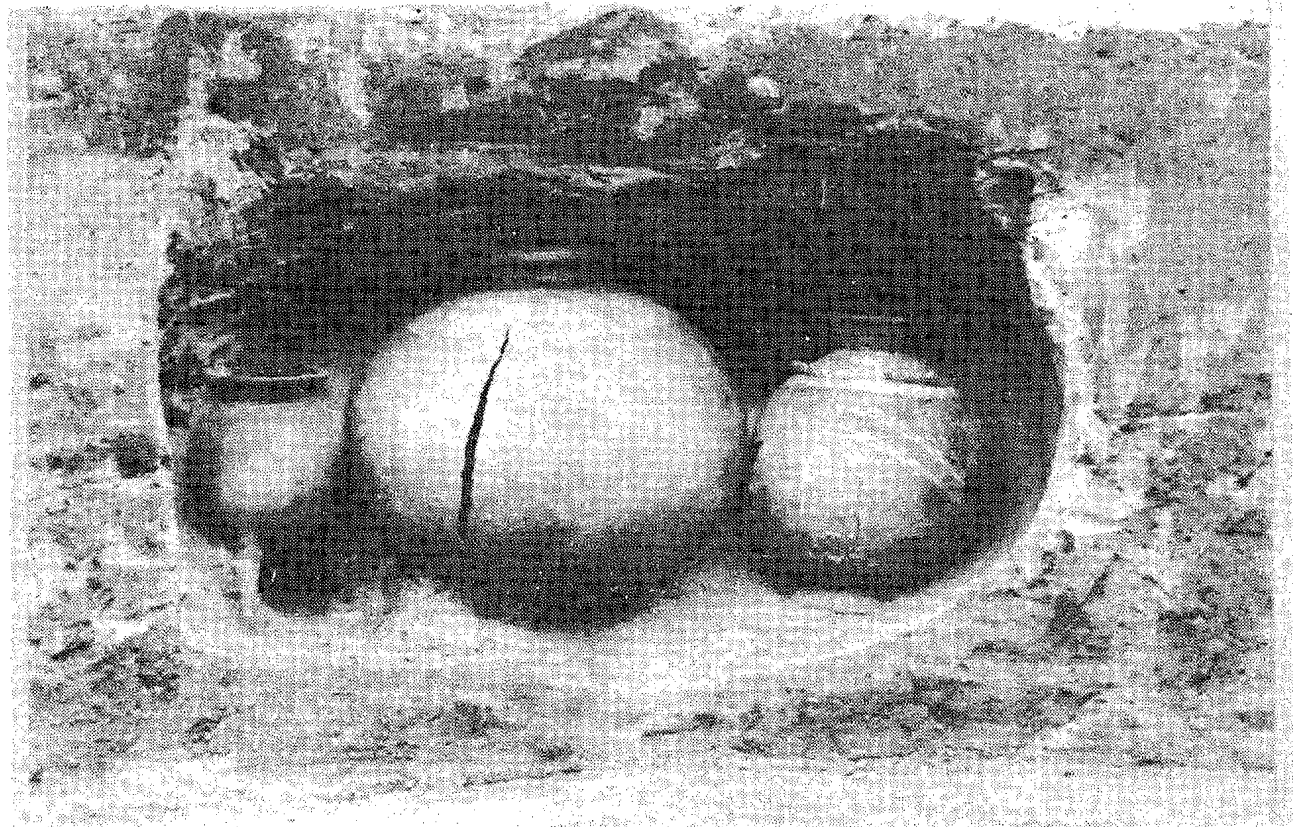

fig. 2 montículo n, nicho este

Lam. IV

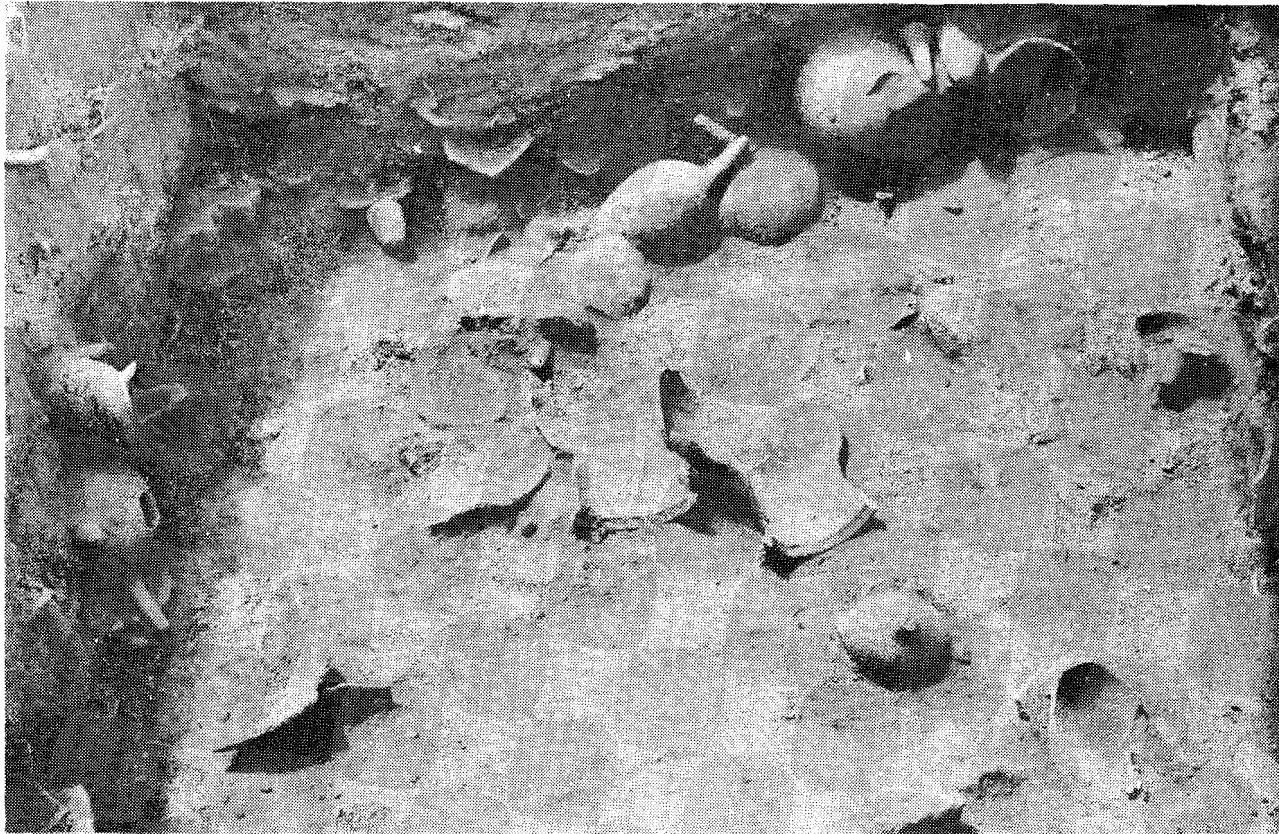

fig. 1 pueblo, S 22, perfil N/O



fig. 2 pueblo, perfil O/W 3 b, tumba 3

Lam. V

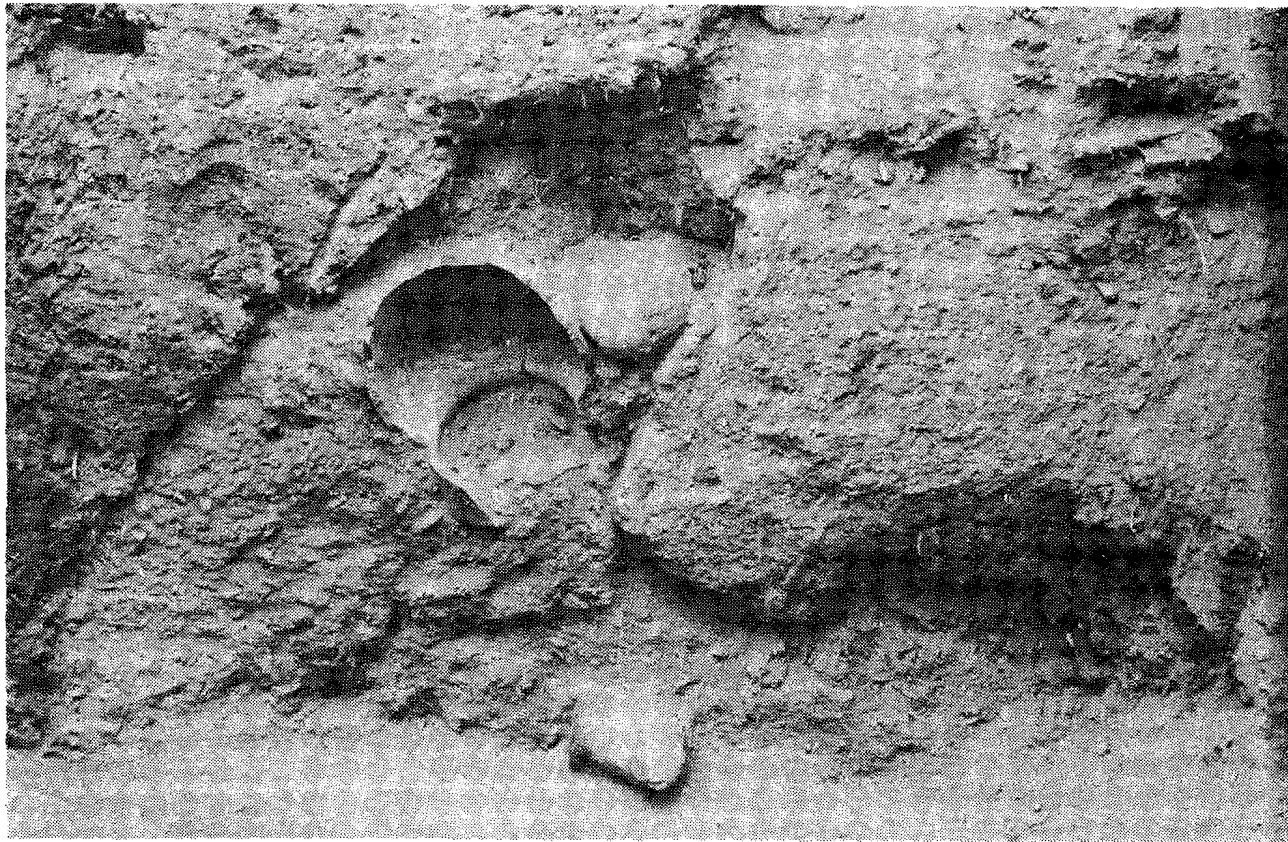

fig. 1 pueblo, S 8, perfil N, tumba 5

Lam. V



fig. 2 pirámide E, excavación de las "grachas" cerca de la rampa

Lam. VI



fig. 1 pirámide E, moldes con piedras, plancha central

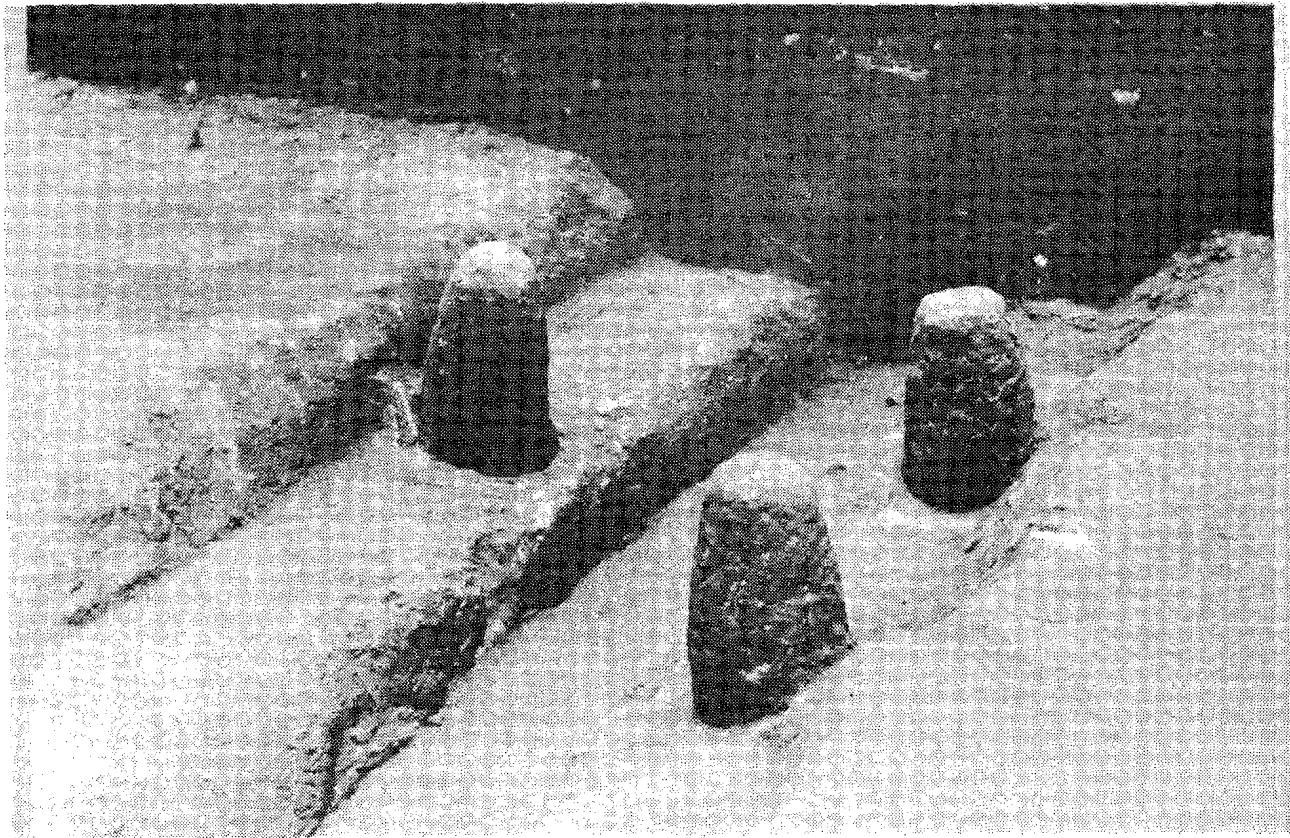

fig. 2 pirámide E, piedras, planchas central.

Lam. VII

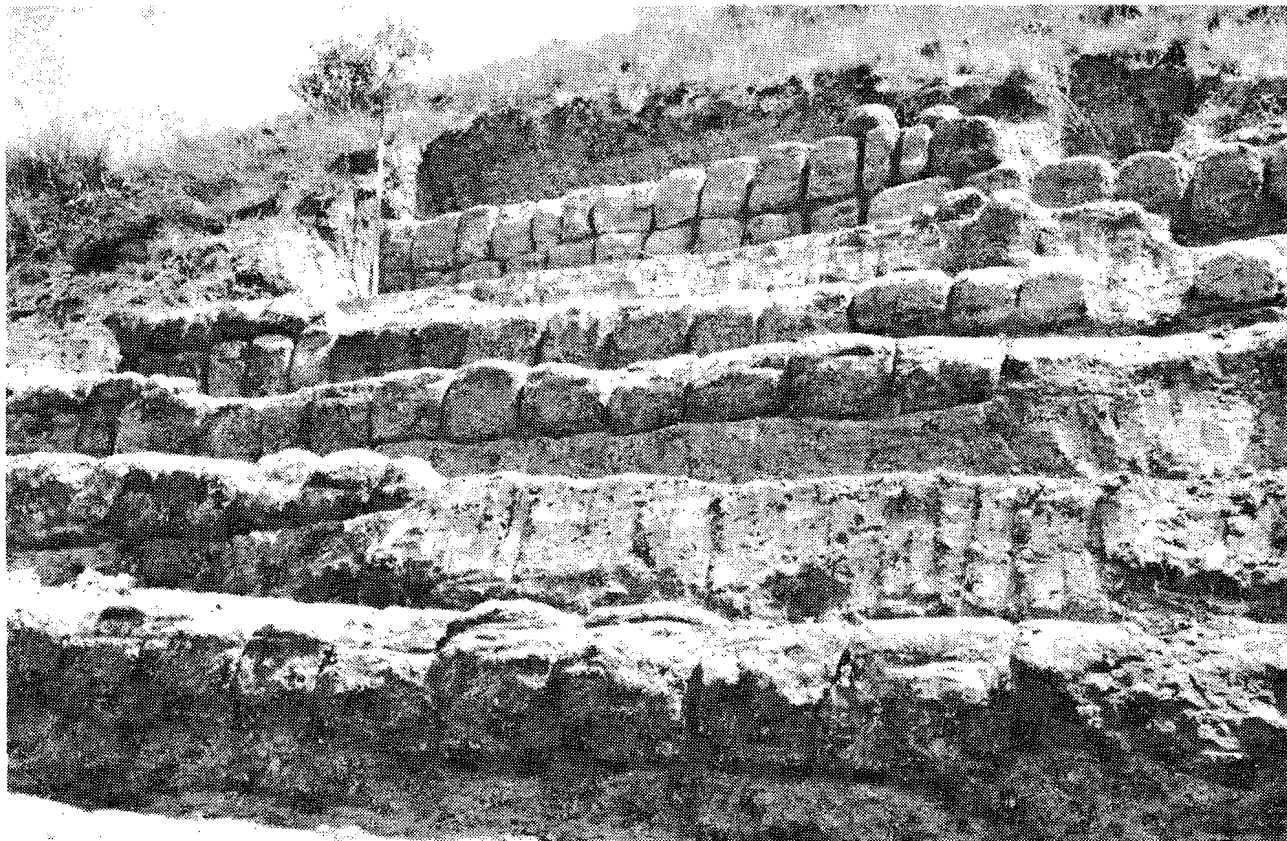

fig. 1 pirámide G, escalonamiento de bloques de cangagua (parte sur)

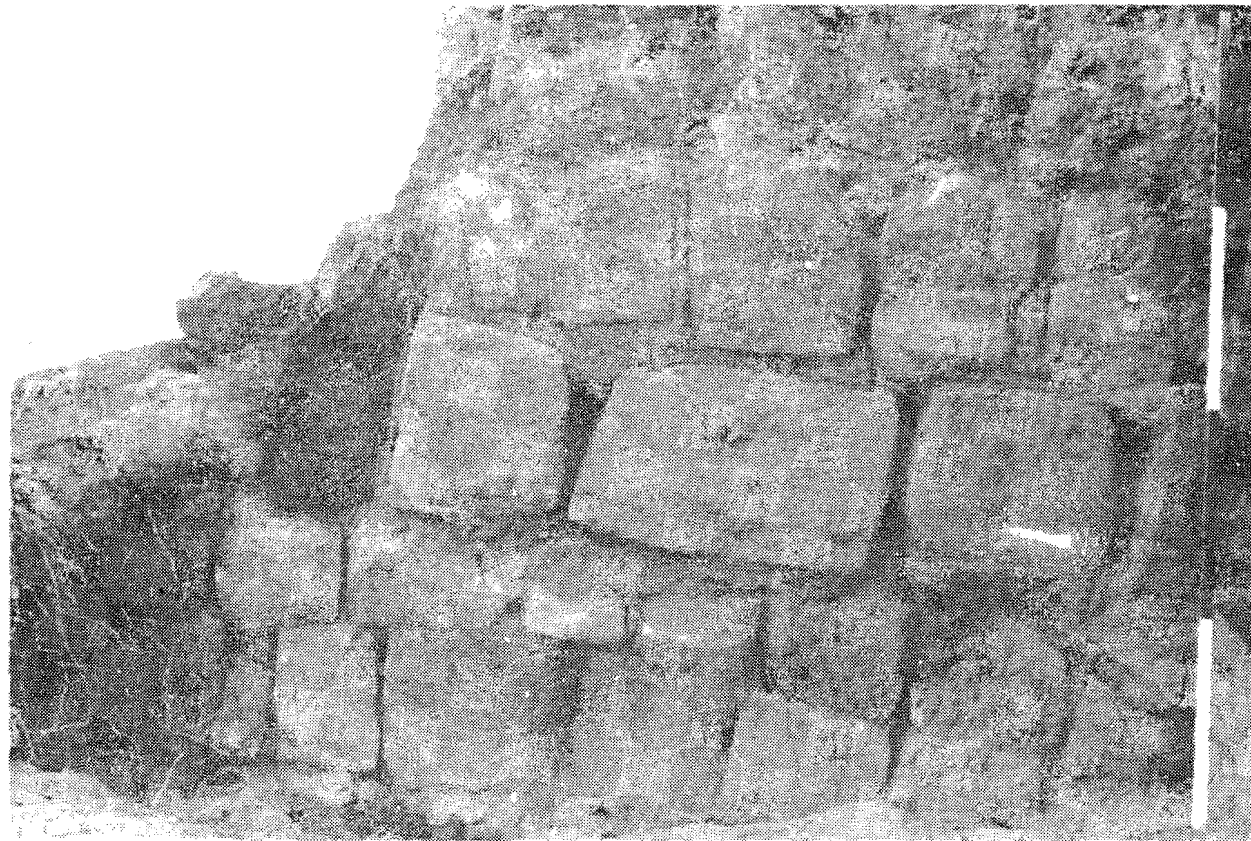

fig. 2 pirámide G, muro de sustención interno de bloques de cangagua en el barro

Lam. VIII

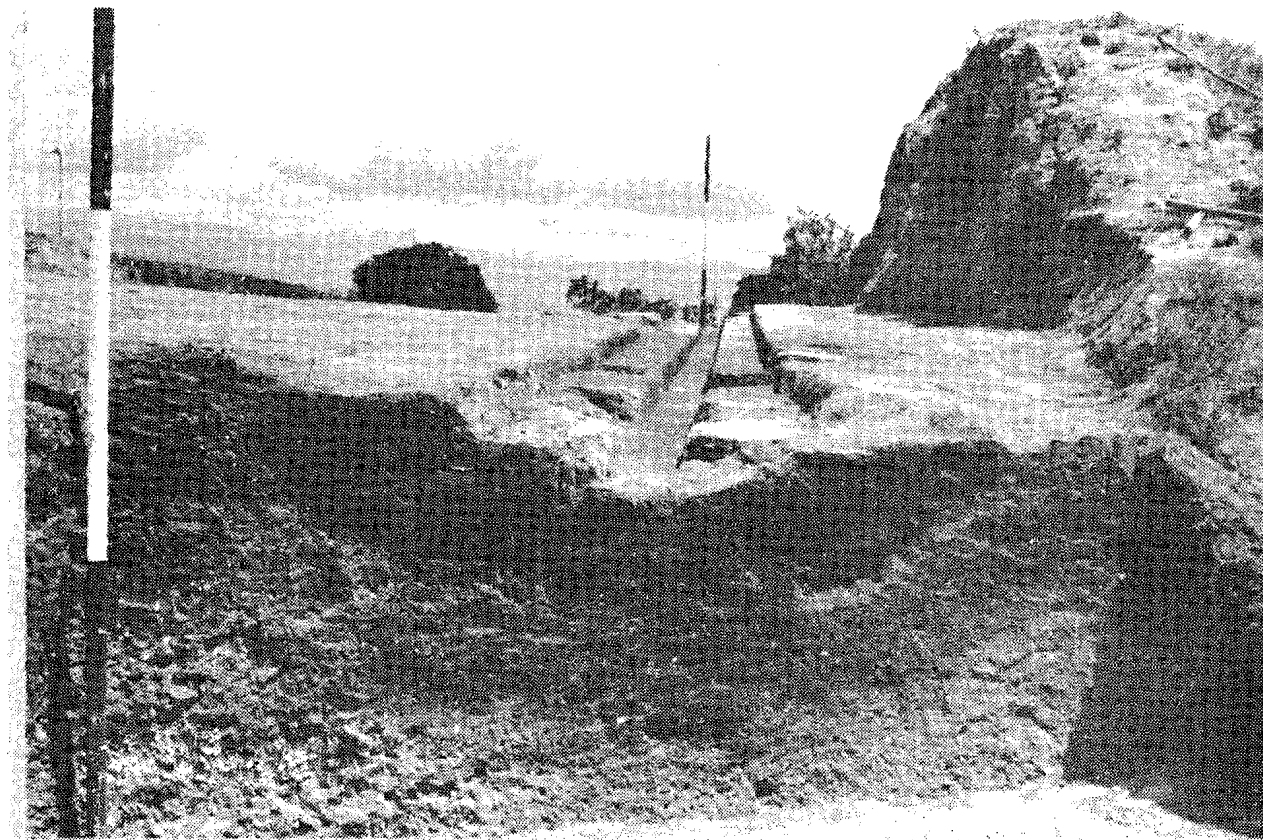

fig. 1 pirâmide G, molde alargado



fig. 2 pirámide H, plancha cocida y molde

B. La Cerámica

Tipo de borde: R

Tipo de decoración: V

Lam. IX

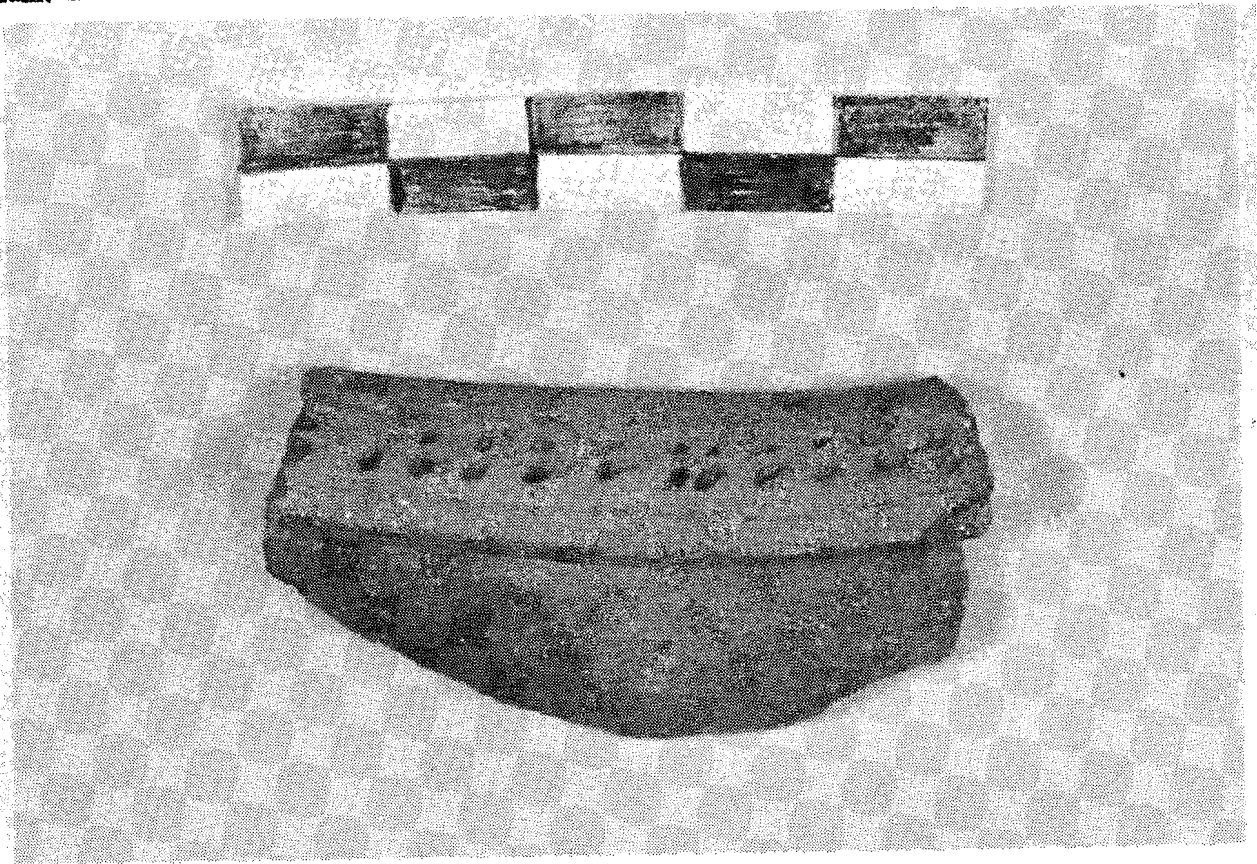

fig. 1 tiesto de borde período I, R. : 10 V. : 2

Lam. IX

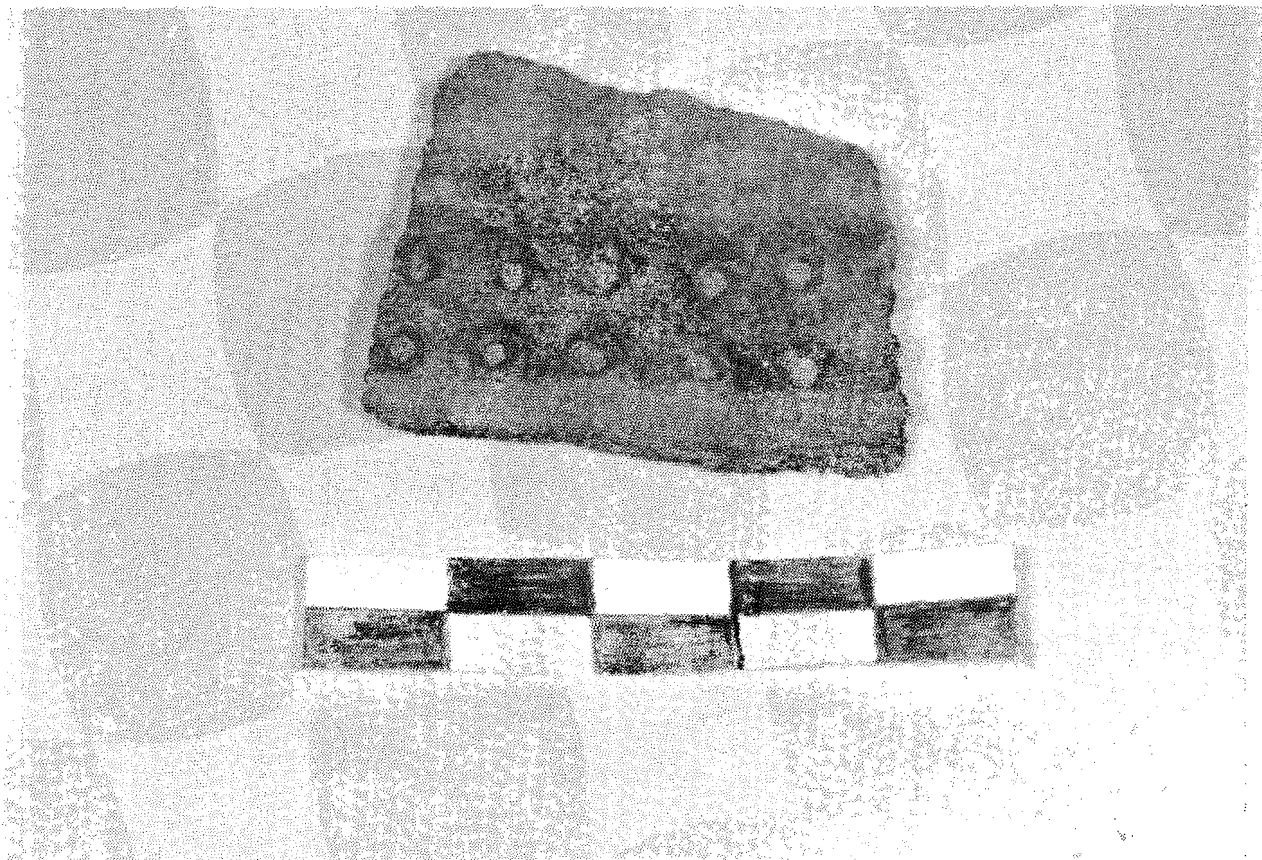

fig. 2 tiesto de pared período I, R.: 7, V.: 3

Lam. X

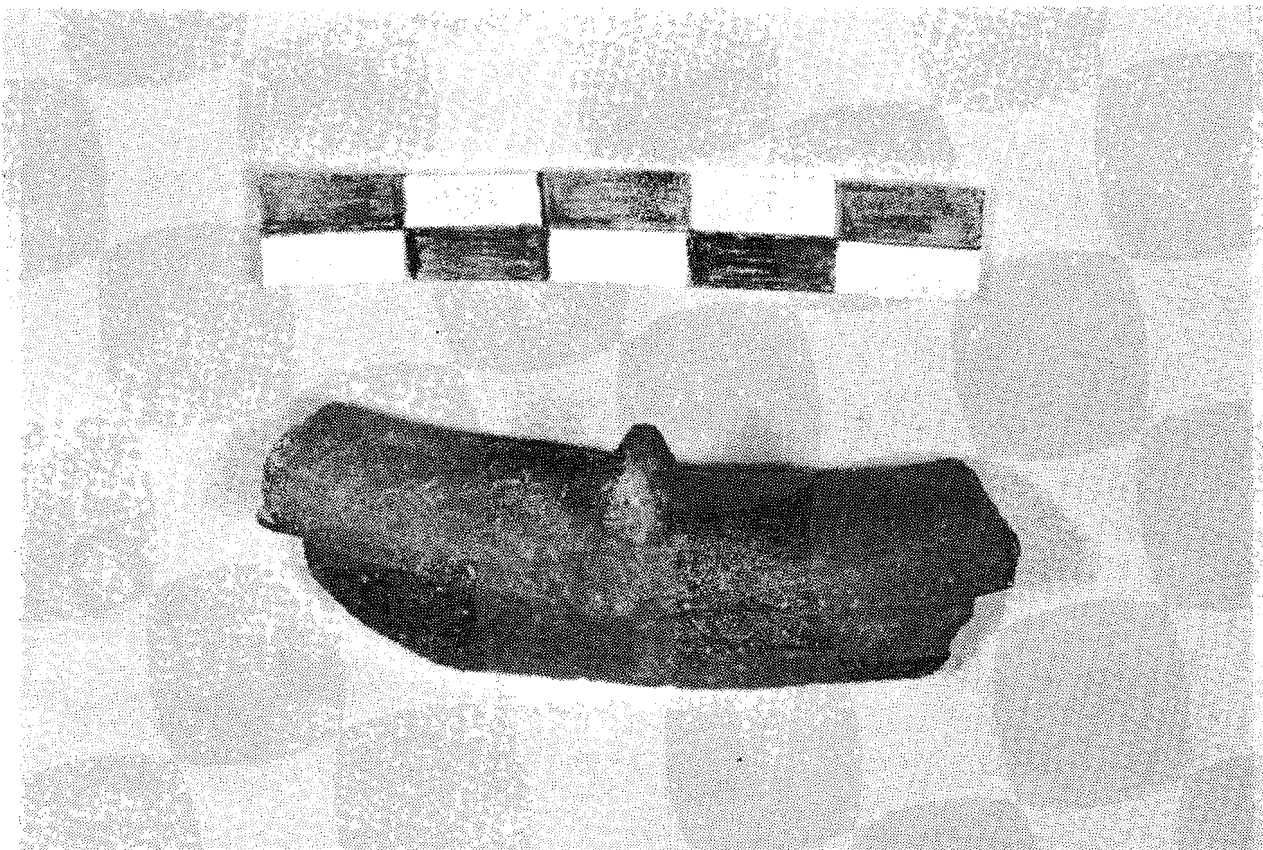

fig. 1 tiesto de borde período I R.: 10. V.: 5

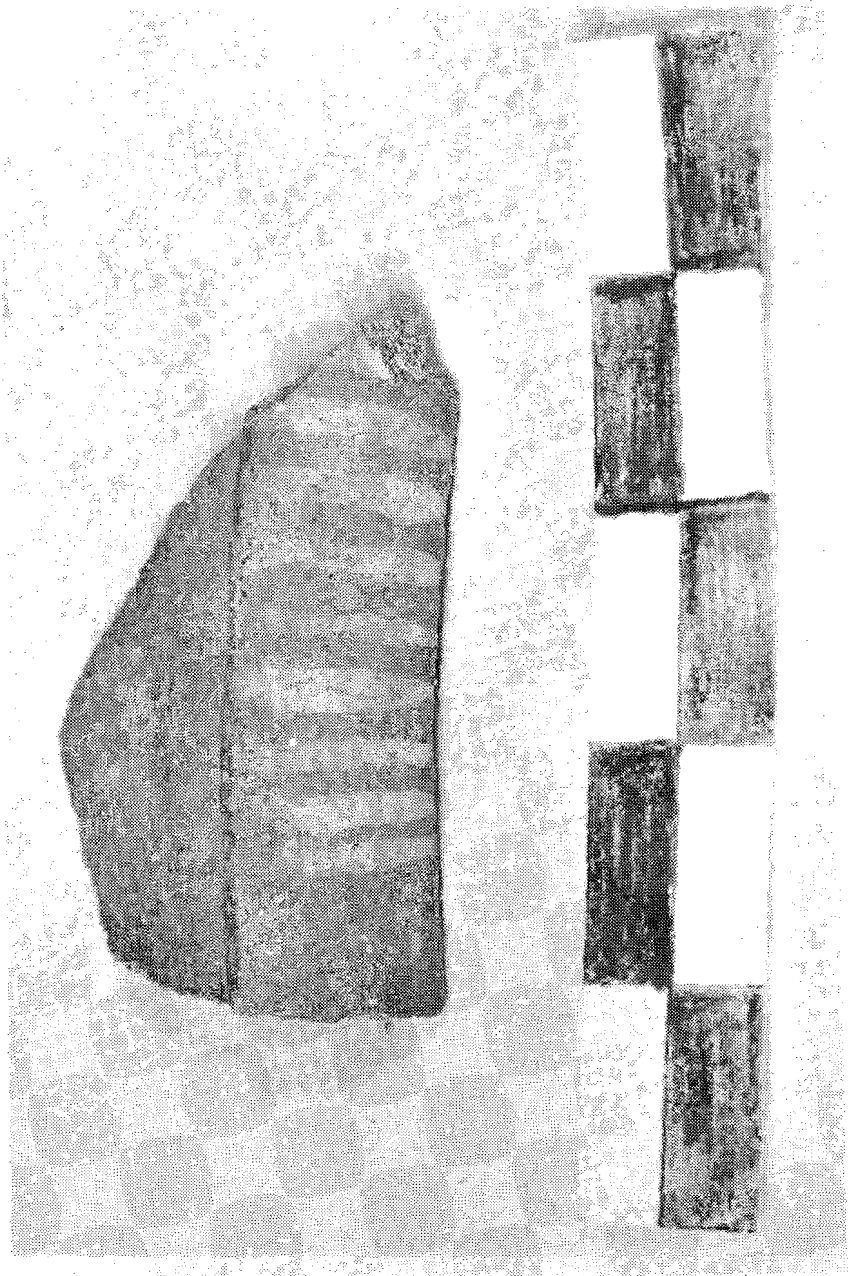

fig. 2 tiesto de borde, periodo I R.: 13, V.: 10:1

Lam. XI

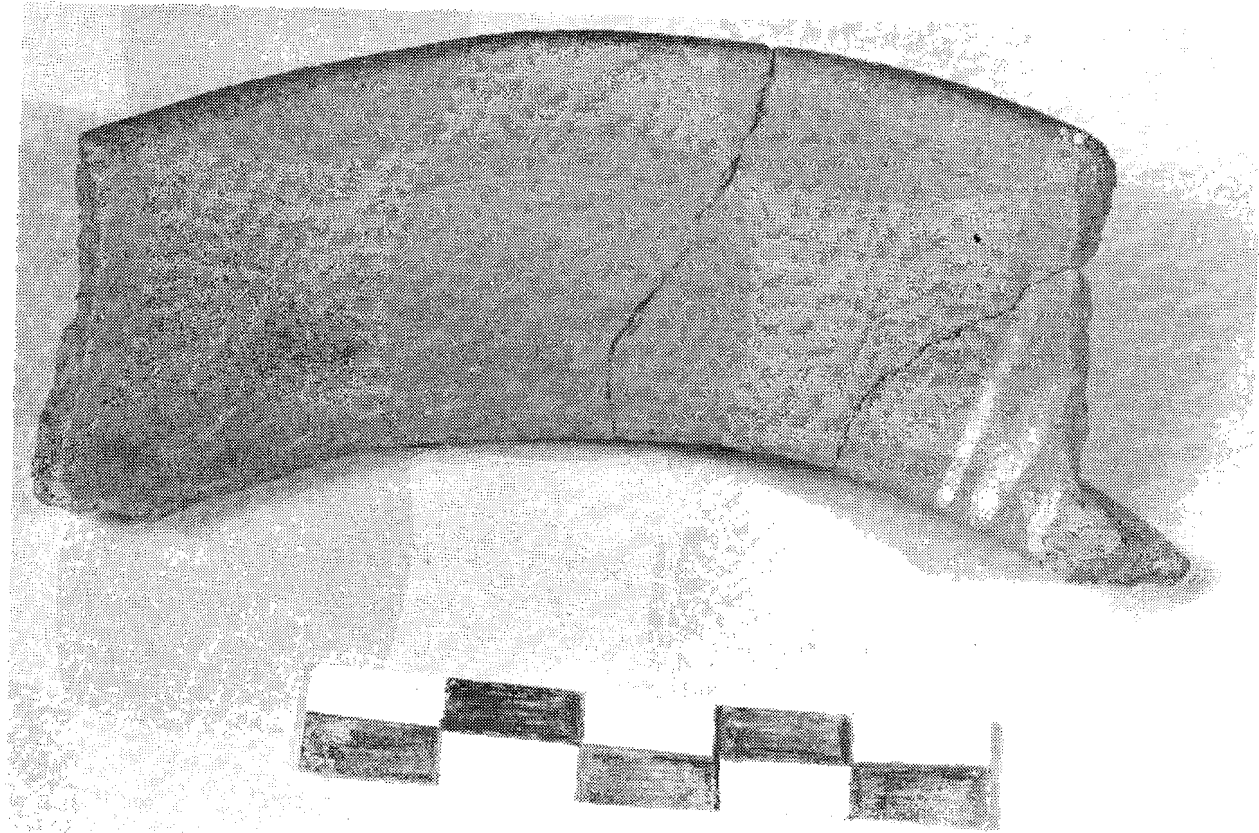

fig. 1 tlesto de borde, periodo I R. : 4, V. : 10.1

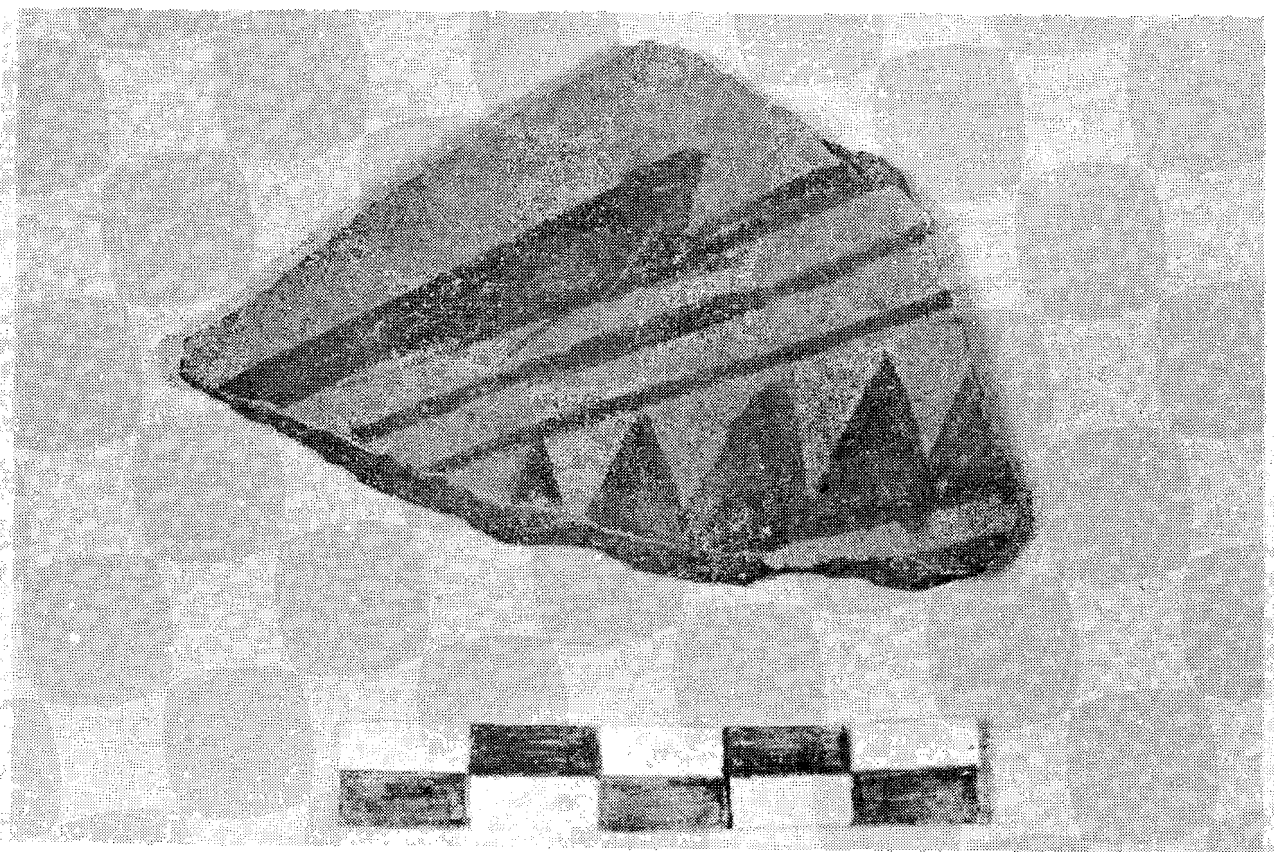

fig. 2 tleso de pared , período I R: ? . V.: 9.1

Lam. XII

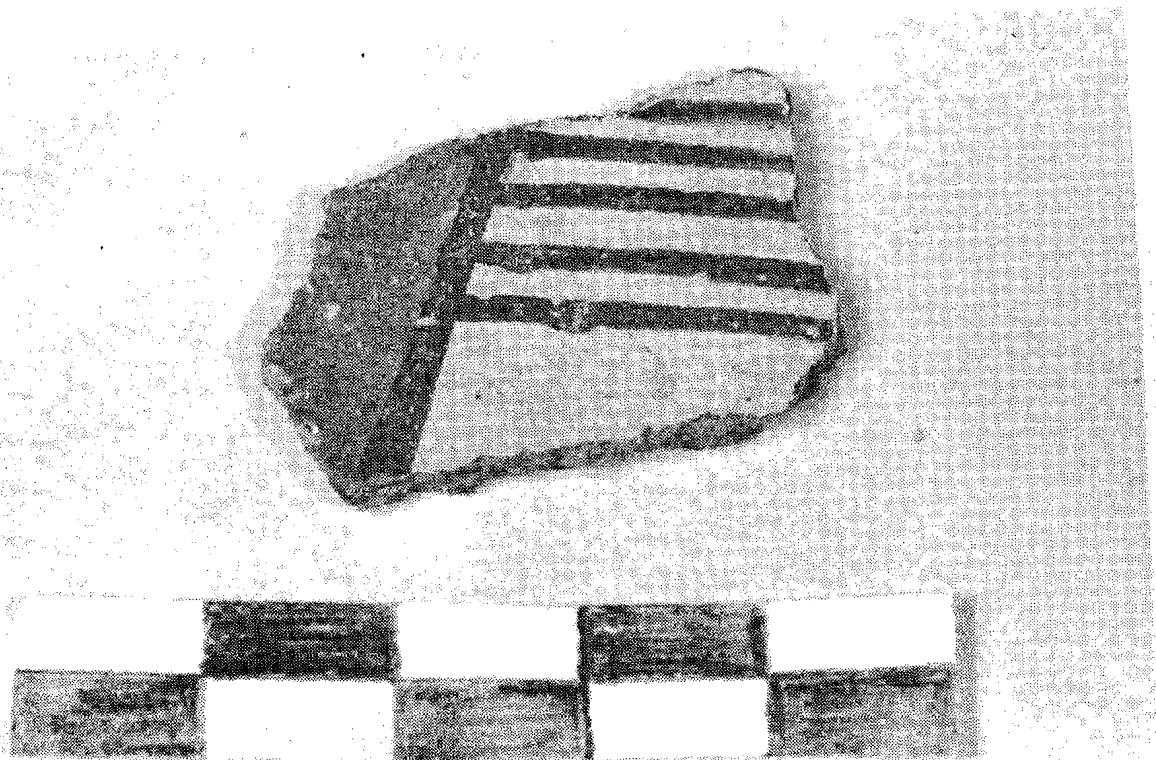

fig. 1 tiesto de pared , fase transitoria I/II, R.: ?, V.: 12.1

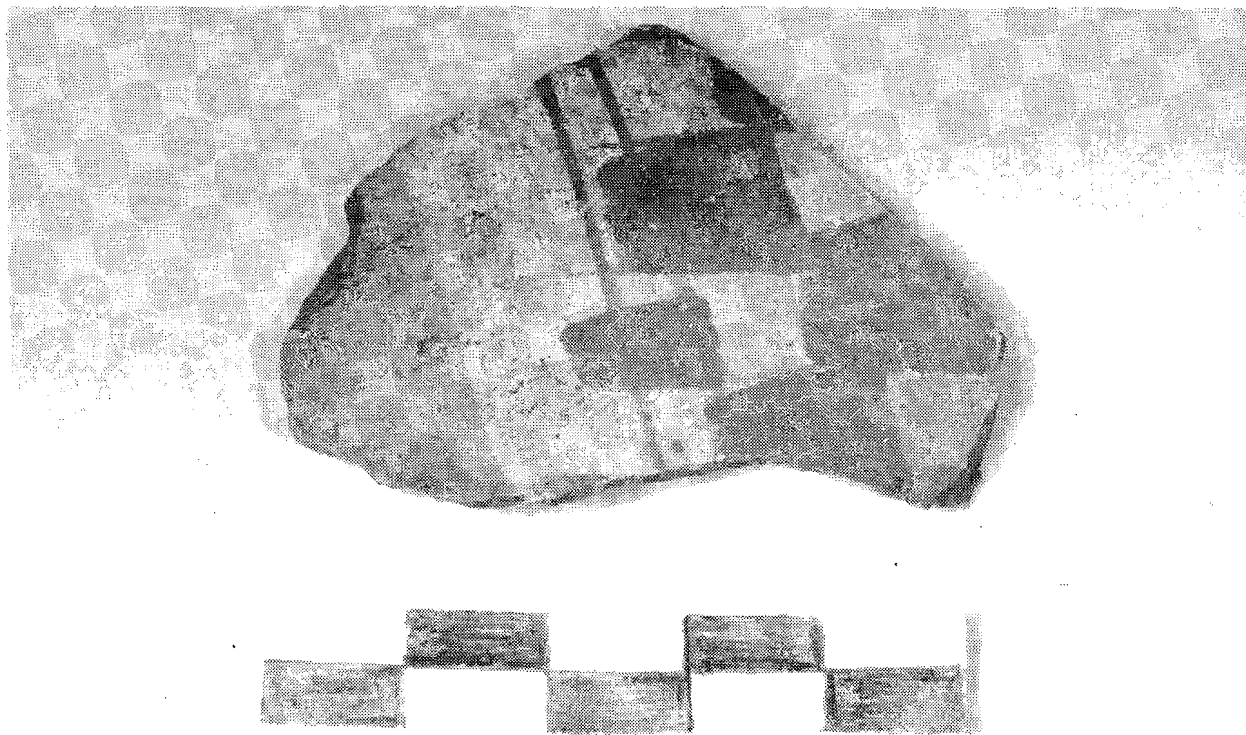

fig. 2 tiesto de pared , fase transitoria I/II, R.: ?, V:12.2

Lam. XIII

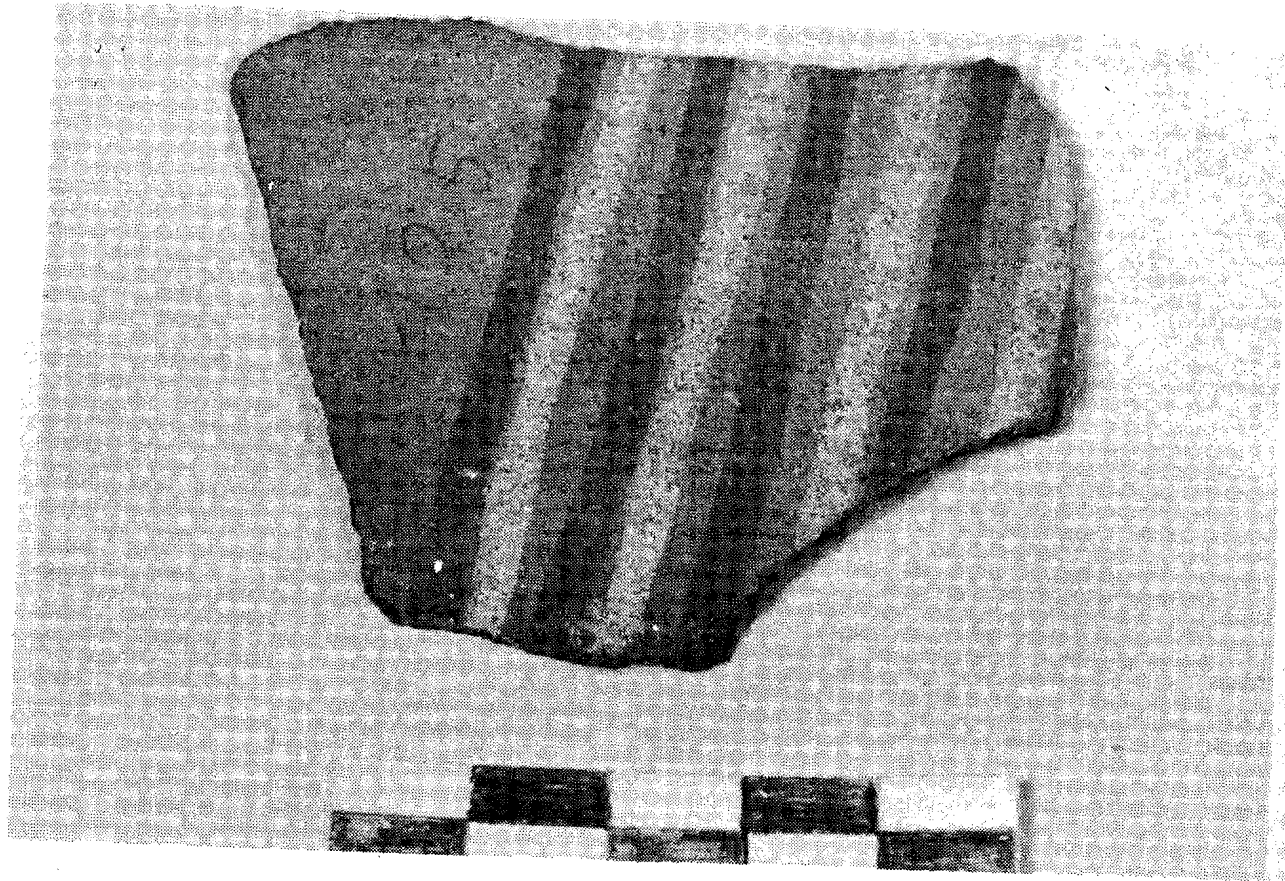

fig. 1 tiesto de pared , perlodo II R. : 2, V. : 11.1

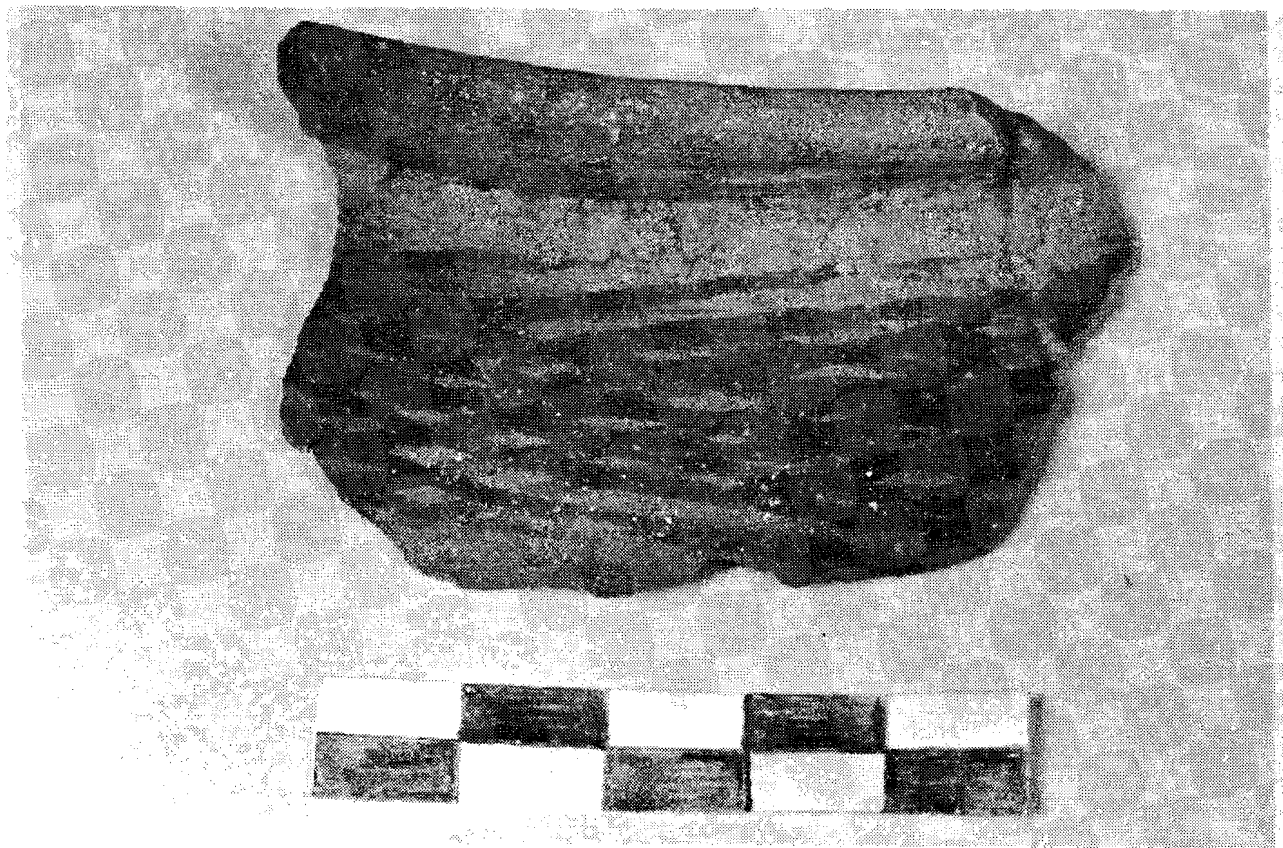

fig. 2 tiesto de borde, período II R.: 11. V.: 9.4

Lam. XIV

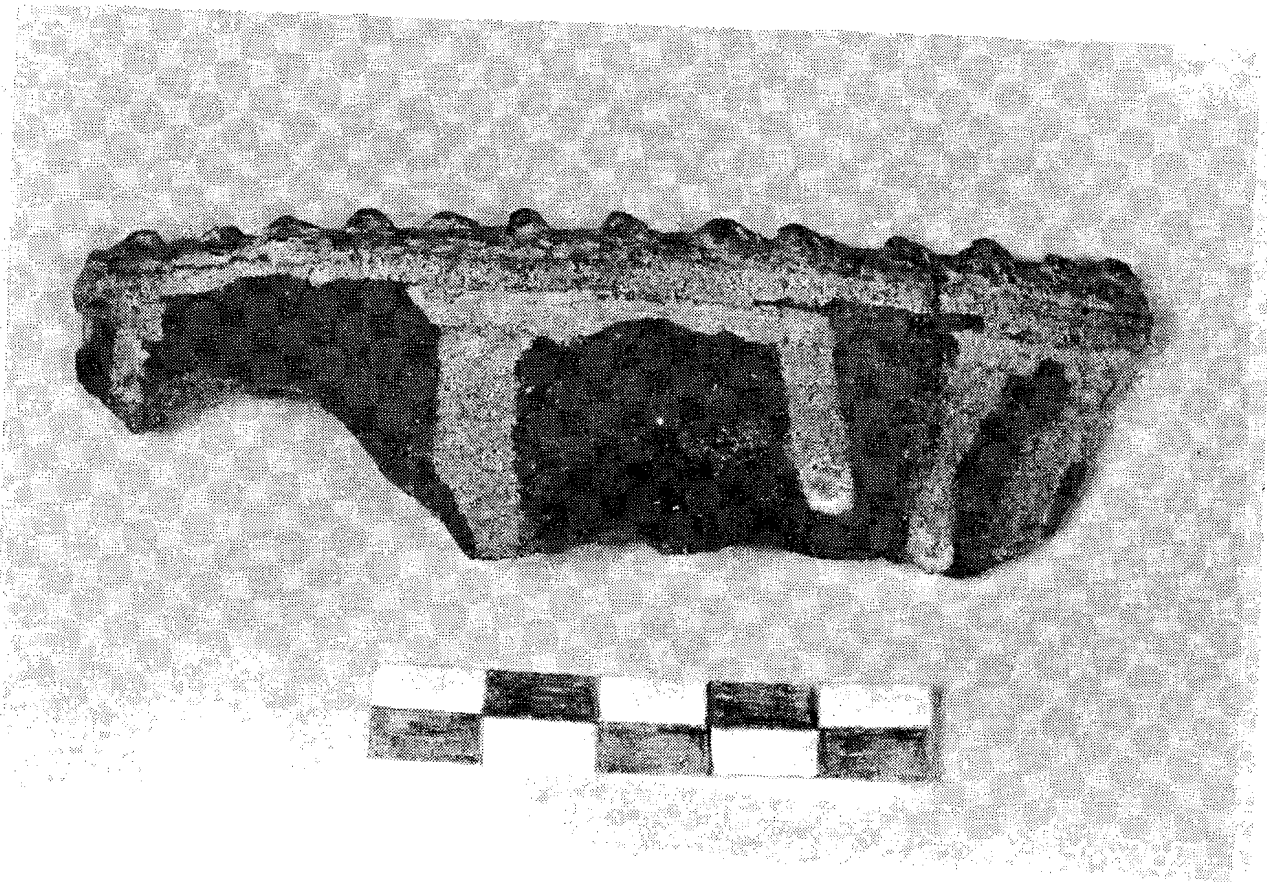

fig. 1 tlesto de borde, periodo II R. : 12, V. : 7 + 10.2

Lam. XIV

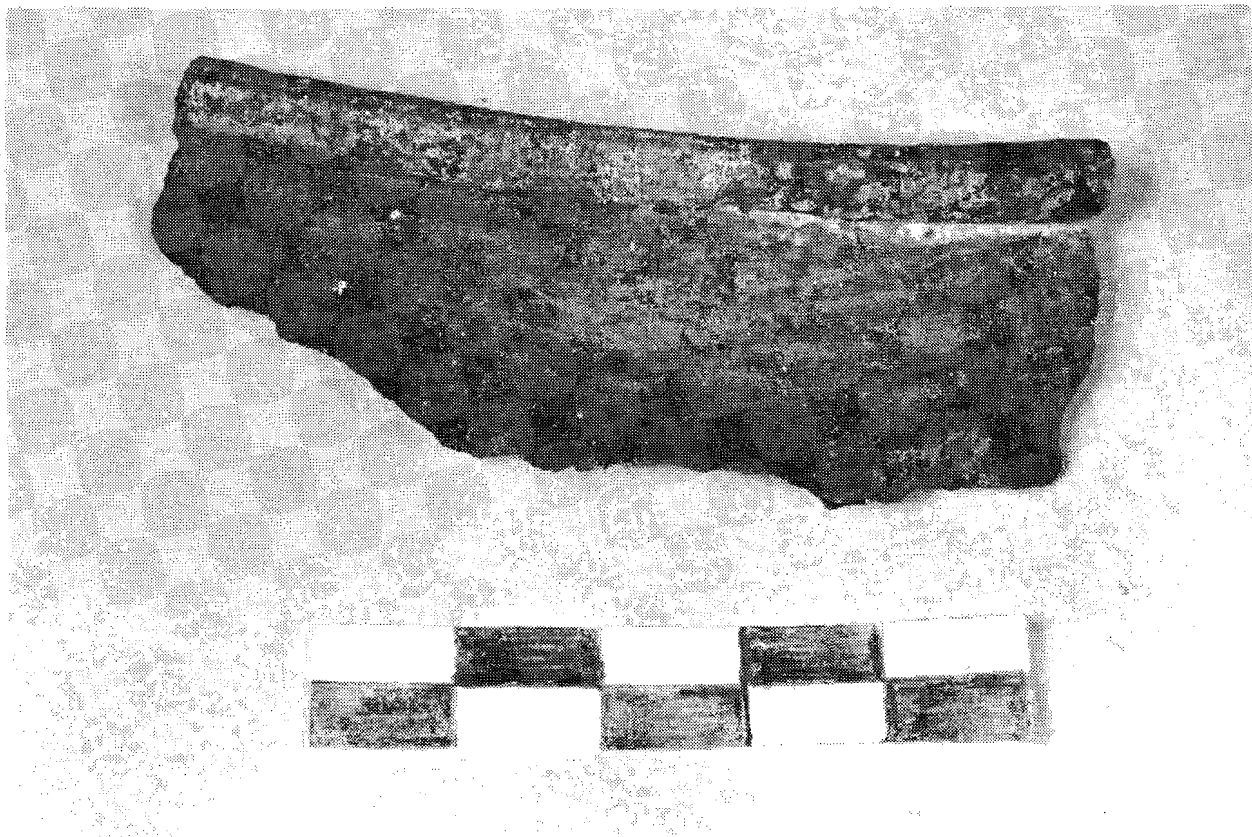

fig. 2 tiesto de borde, período II R.: 12, V.: 9.4 + 10.2

Lam. XV

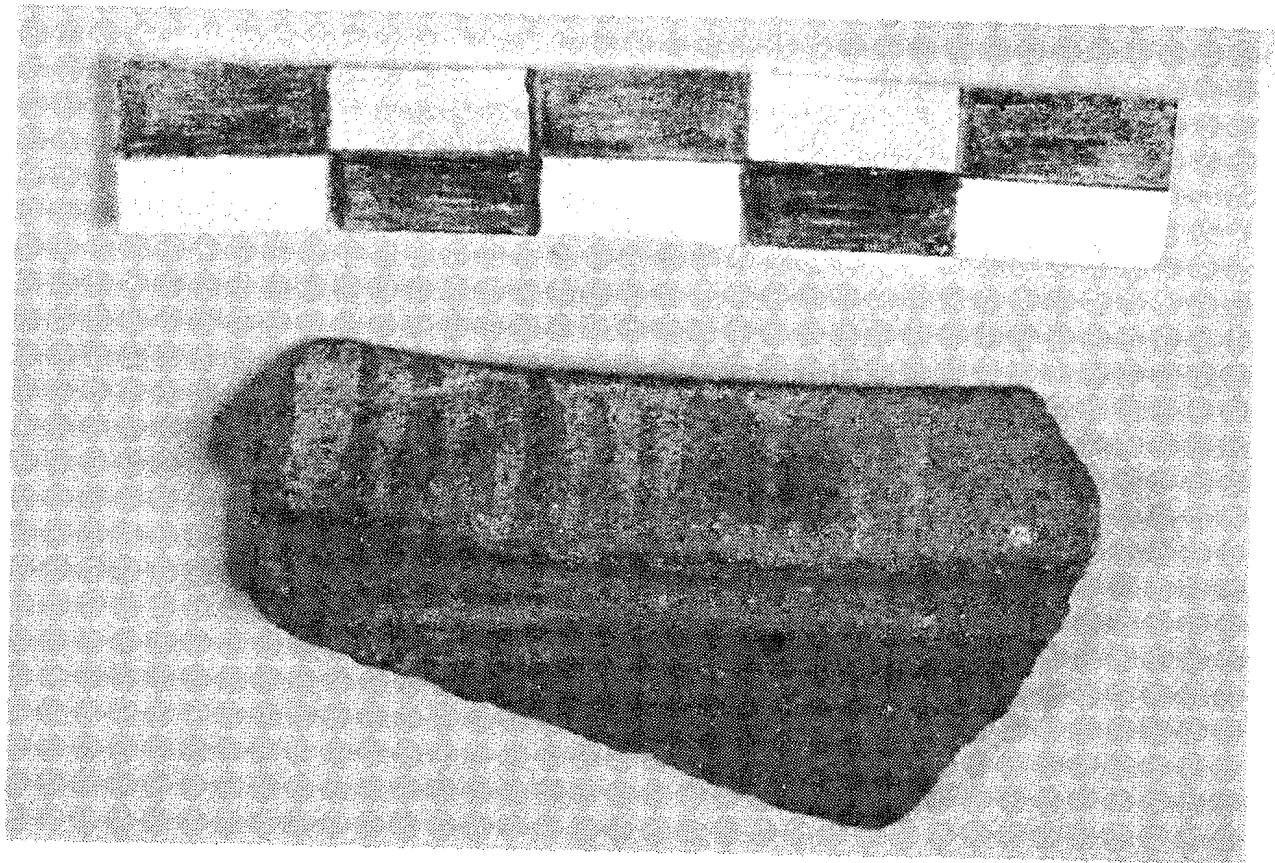

fig. 1 tiesto de borde, período II R. : 12, V. : 10.3

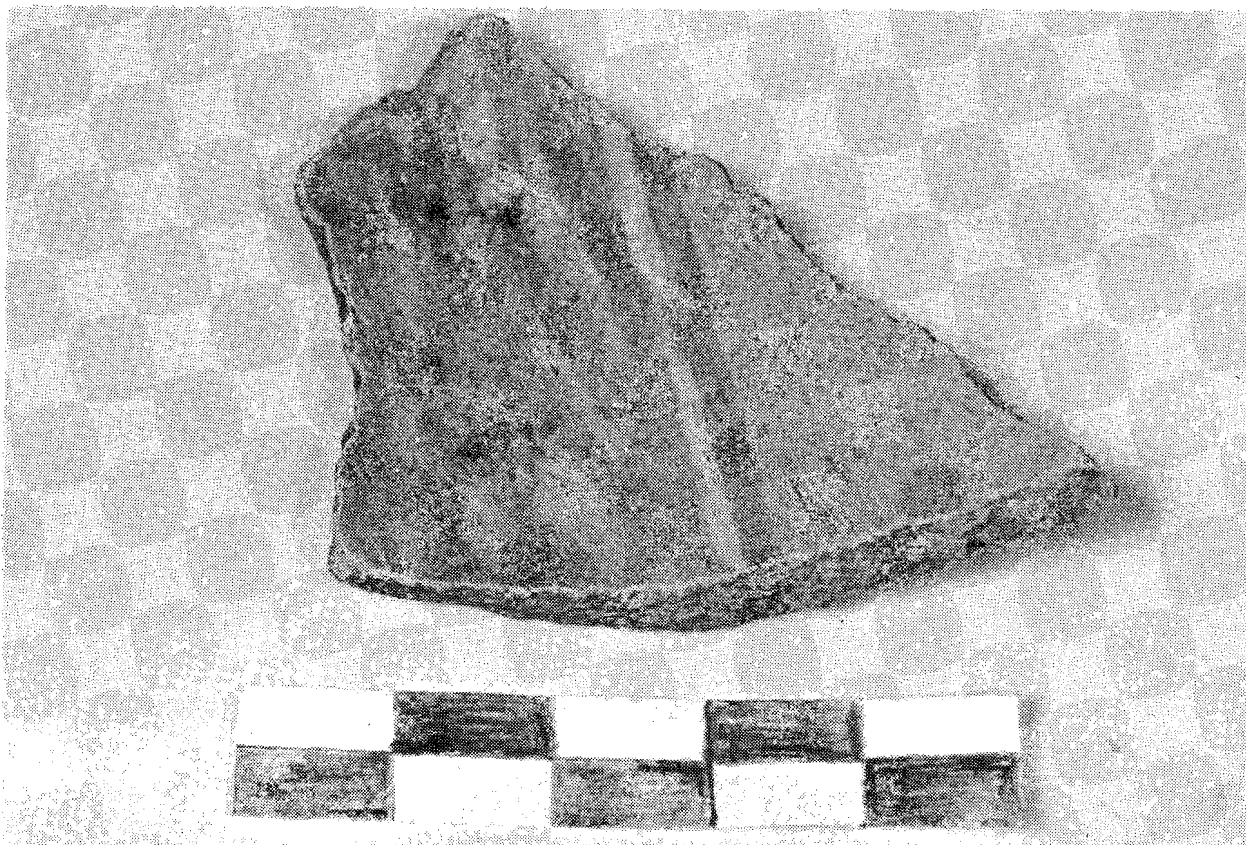

fig. 2 tiesto de pared , período II R.: ?, V.: 11.6

C. Figurinas



fig. 1 figurina (sólida), tipo 1.3.1. I período I



fig. 2 figurina (sólida), tipo 1.3.4, III, período I

Lam. XVII



fig. 1 figurina (sólida), tipo 1.3.1, IV período I



fig. 2 figurina (sólida), tipo 1.3.1, V período I

Lam. XVIII



fig. 1 figurina (sólida), tipo 1.3.1, VI período II

Lam. XVIII



fig. 2 figurina (hueca), tipo 1.3.2, I período II

D. Fragmentos de vasijas antropo-/zoomorfas

Lam. XIX

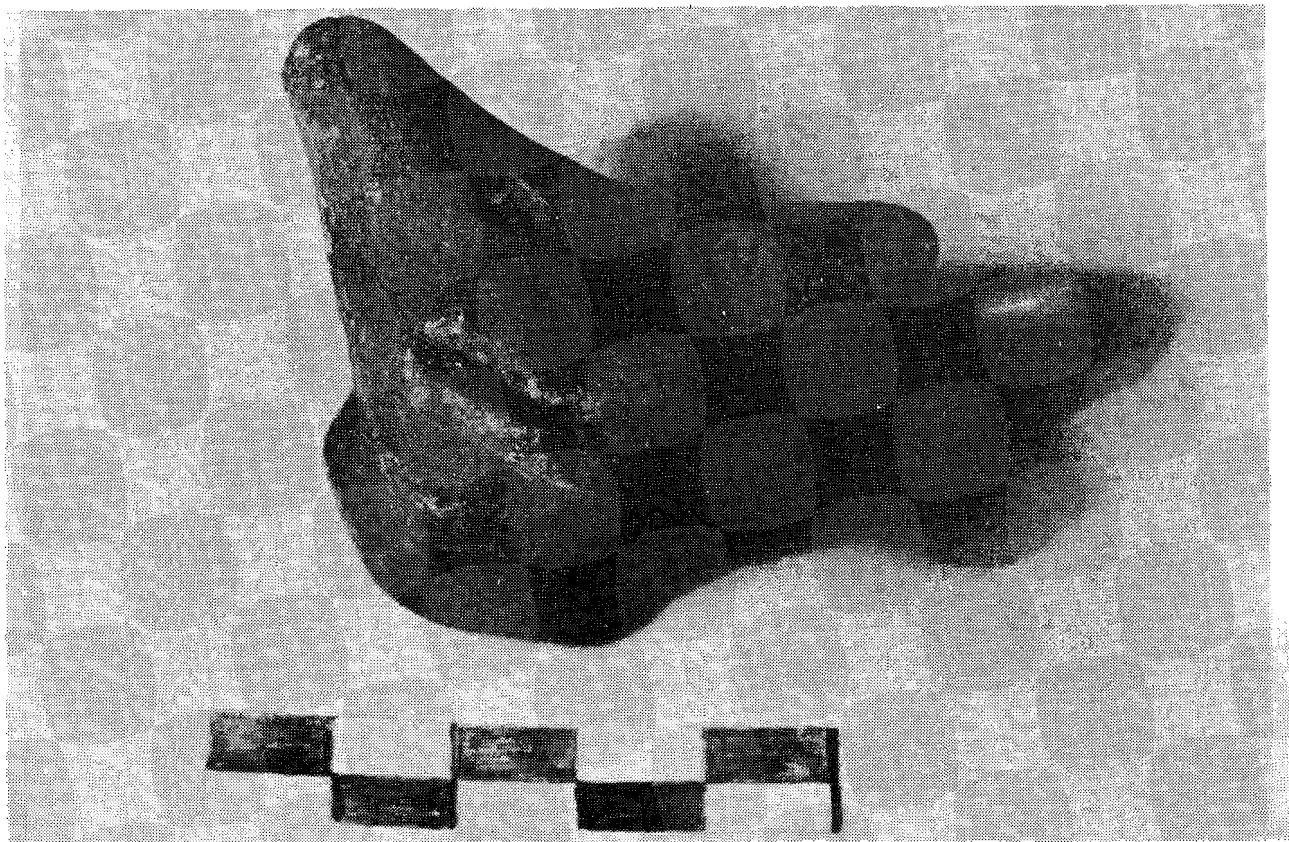

fig. 1 frammento zoomorfo tipo 1.3.4/e, periodo II



fig. 2 fragmento, brazo, mano y pecho aplicados plásticamente tipo 1.3.3./II,
período II

E. Modelo

Lam. XX

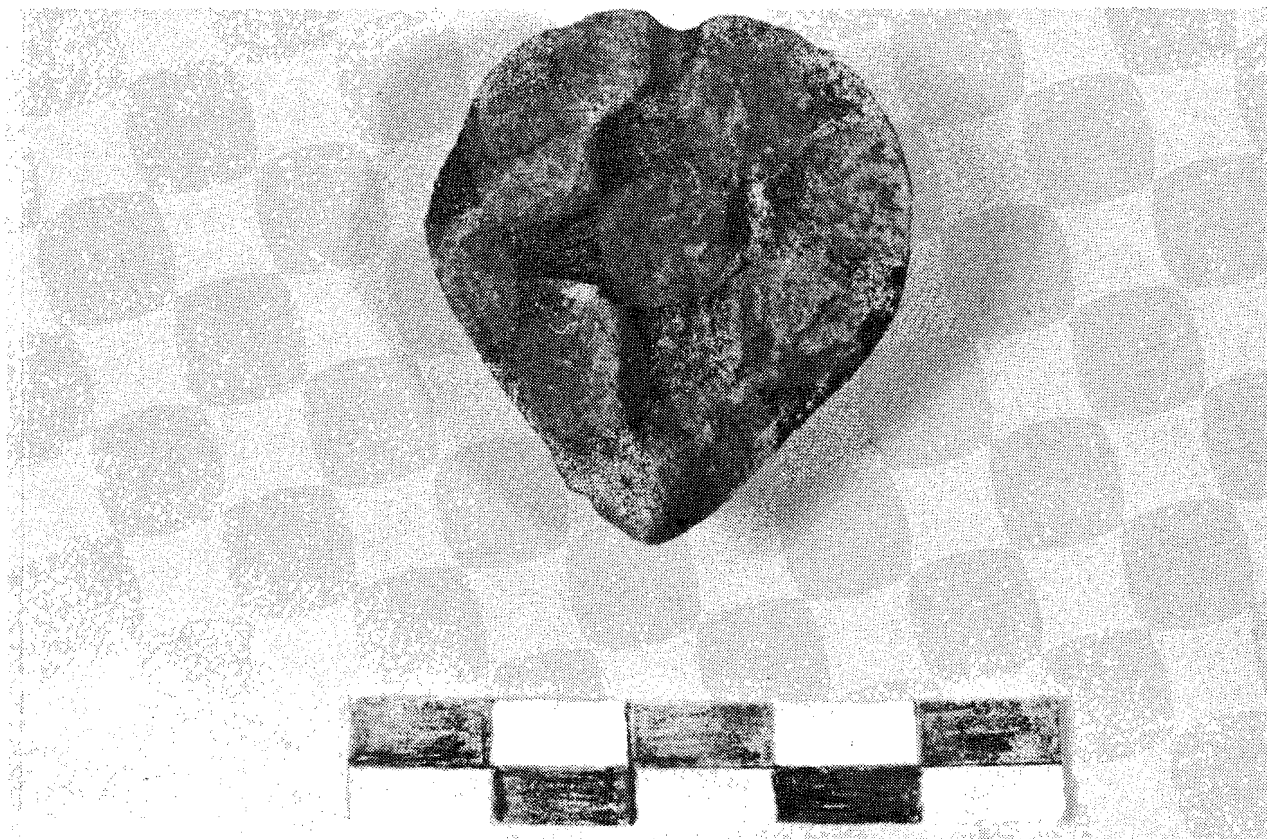

fig. 1 mitad de un modelo ovalado punteagudo, motivo de la vasija:
cabeza de pájaro, período II

F. Artefactos de hueso

Lam. XXI

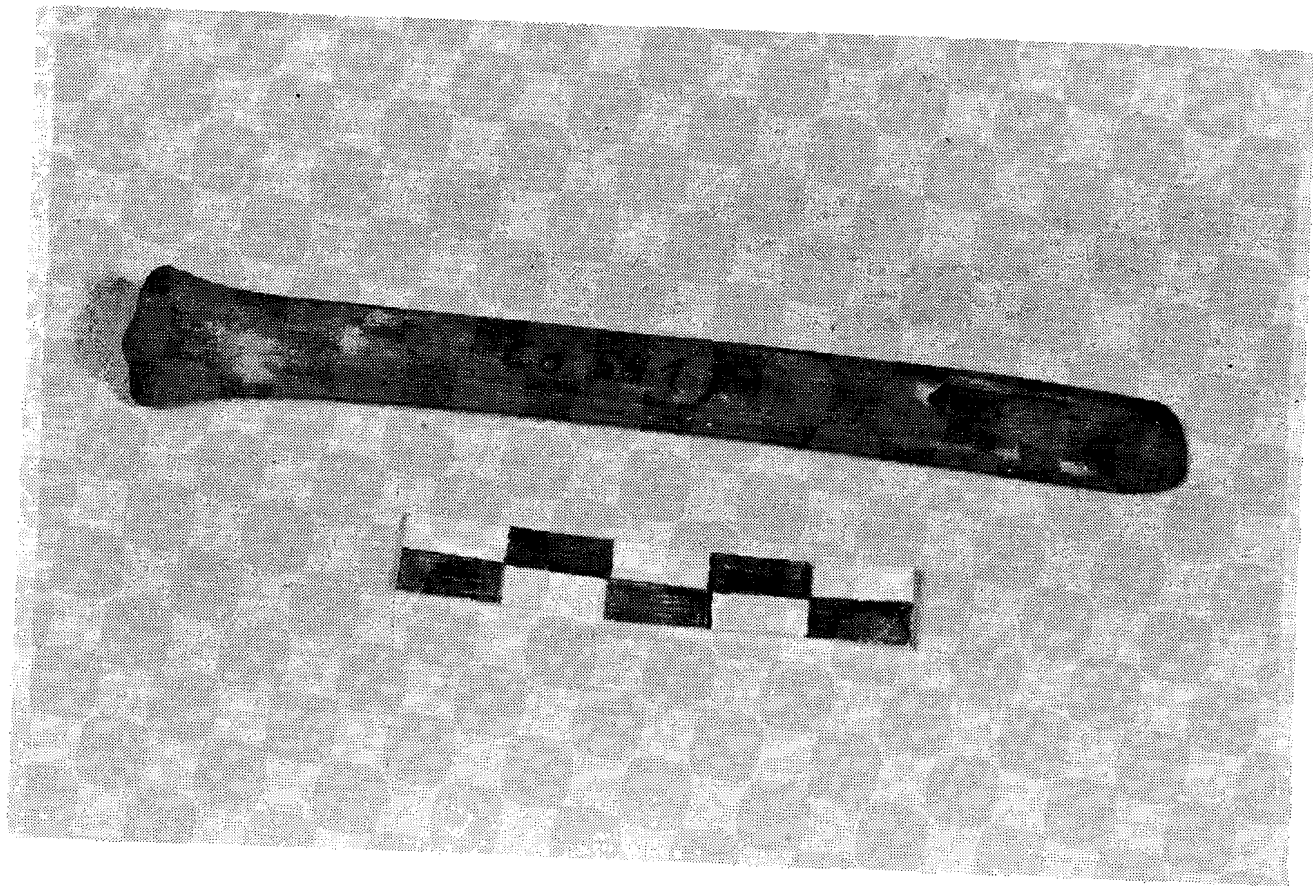

fig. 1 espátula, período I

Lam. XXI

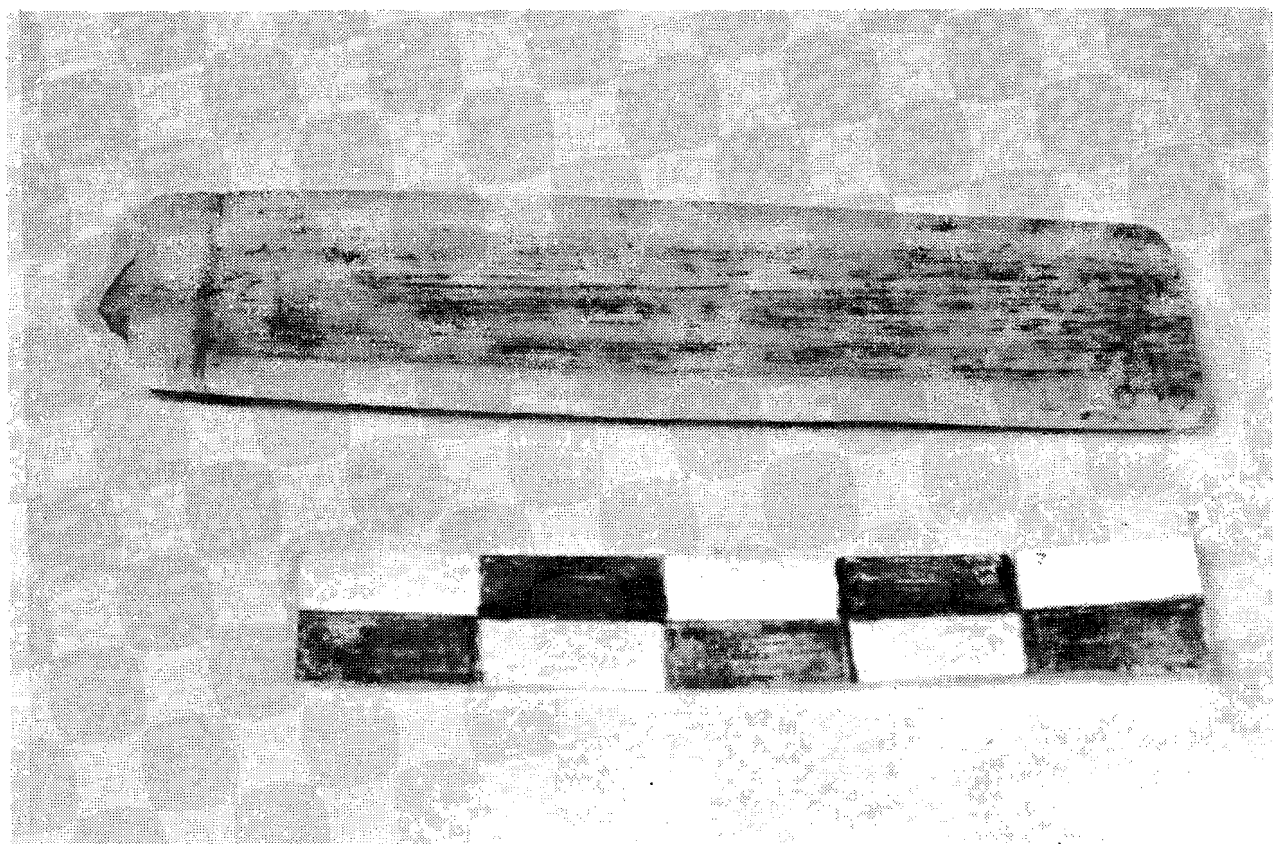

fig. 2 espátula, período II

Lam. XXII

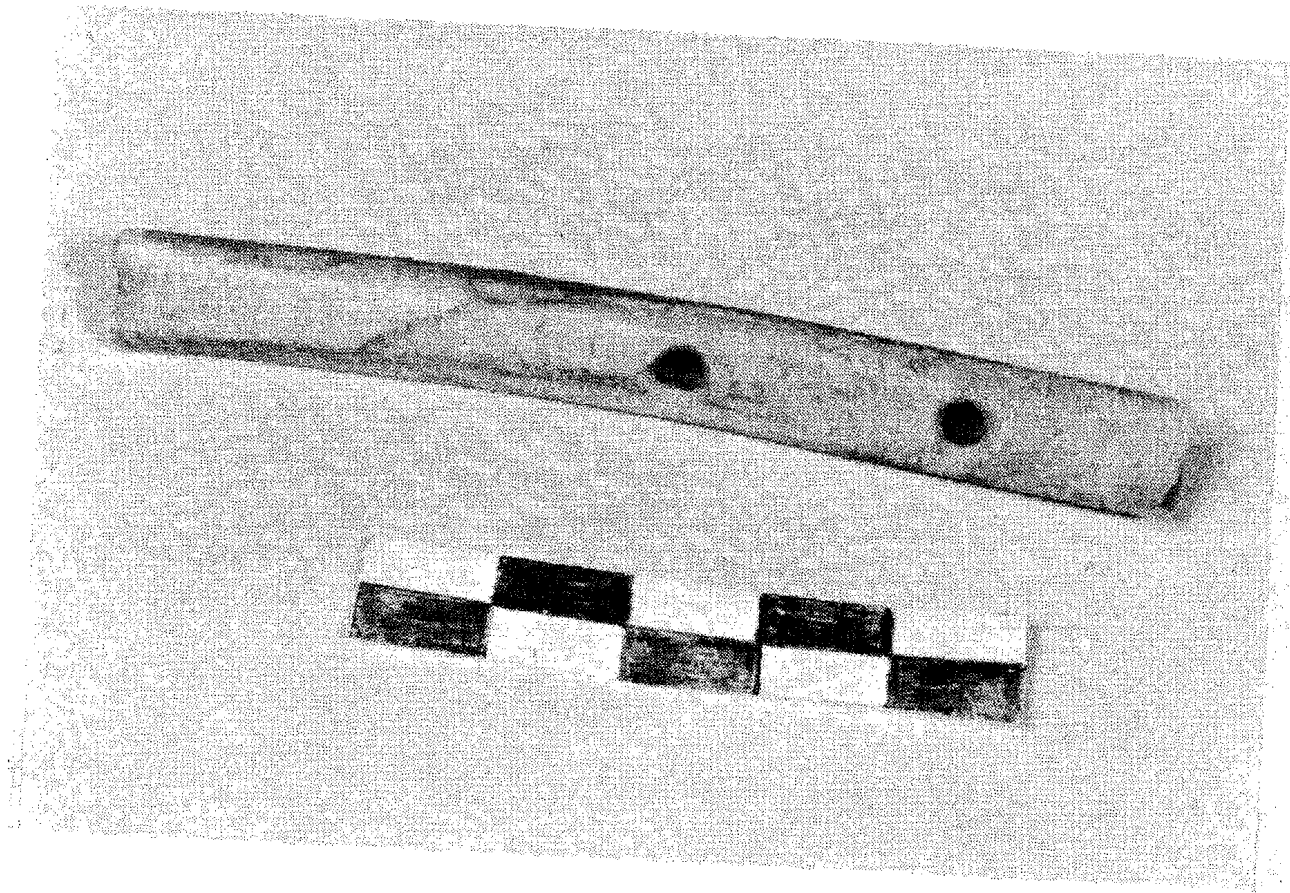

fig. 1 s. fibaro, periodo I

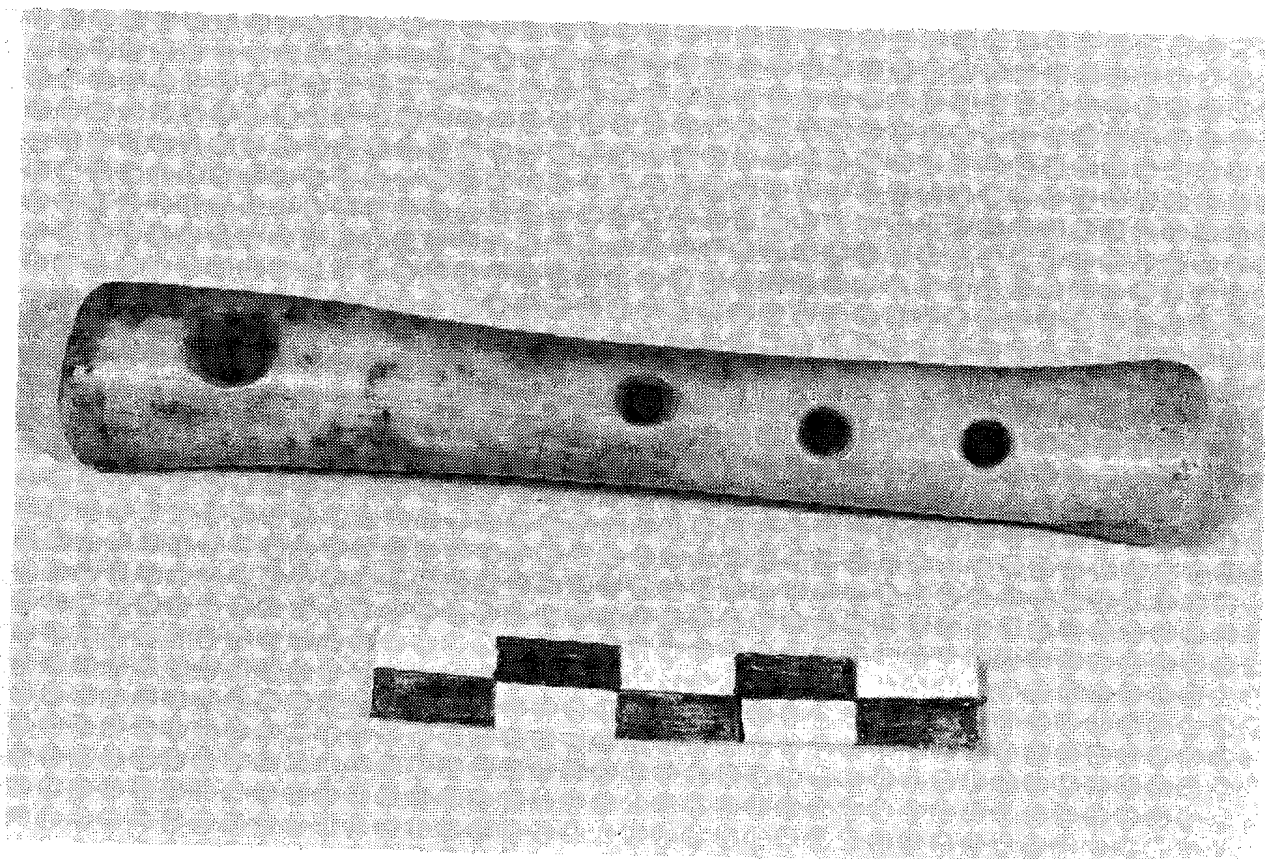

fig. 2 silbato, período II

Lam. XXIII



fig. 1 punta de hueso, periodo I

Lam. XXIII

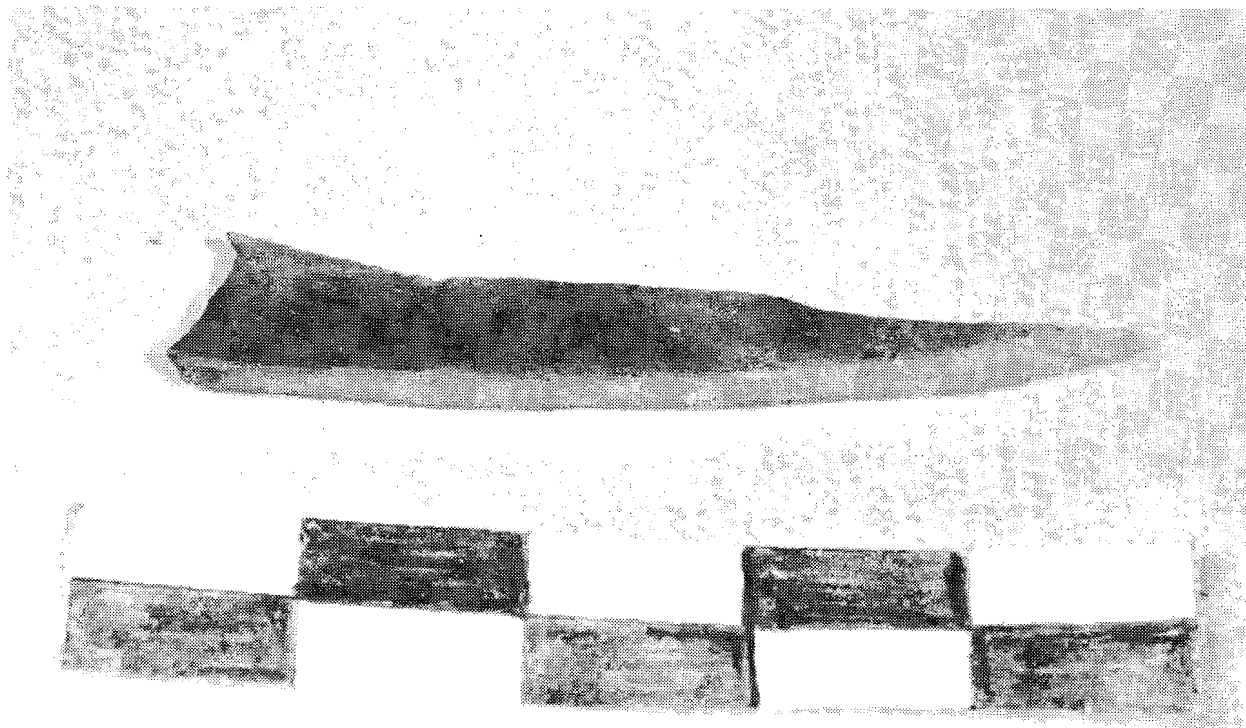

fig. 2 herramienta con función de cortar, rayar, período II

Lam. XXIV



fig. 1 perforador, período I



fig. 2 perforador, período I

Lam. XXV

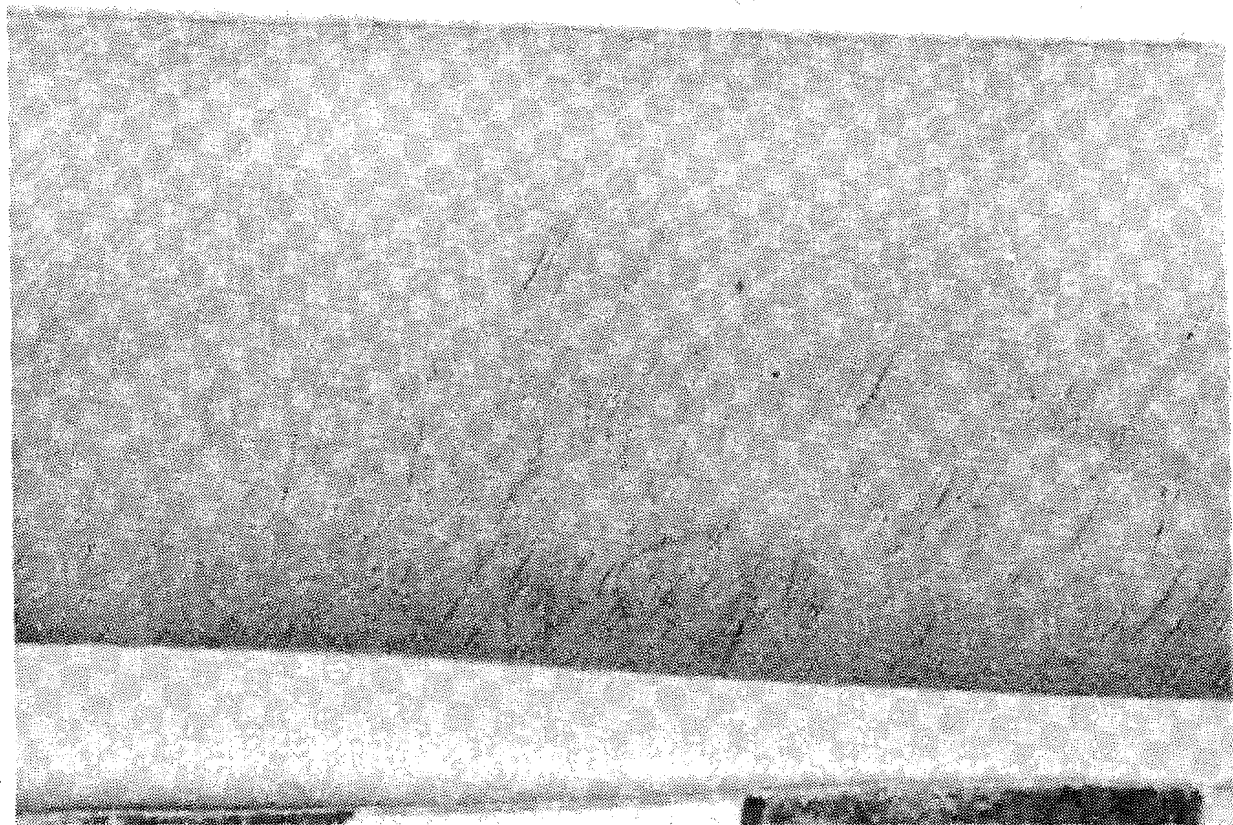

fig. 1 rasgos de cepillar

Lam. XXV

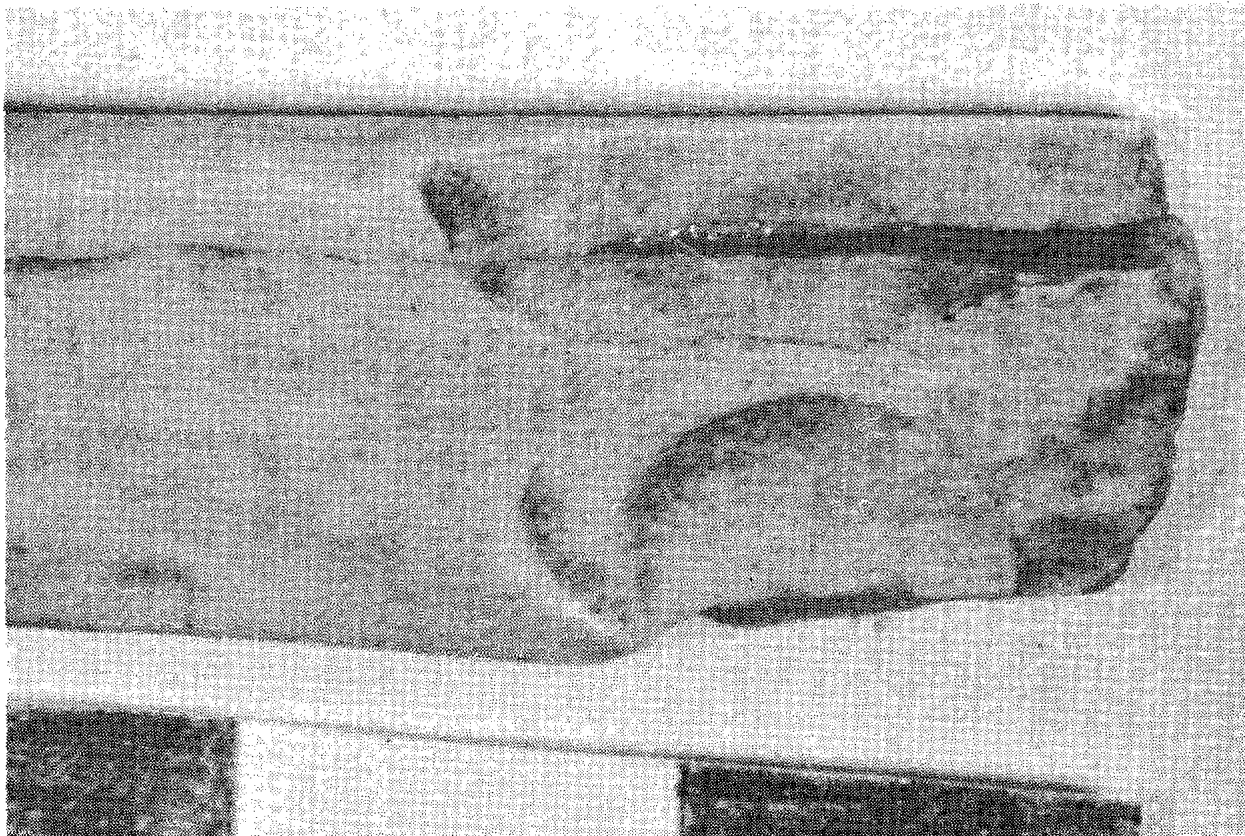

fig. 2 rasgos de golpear

Lam.XXVI

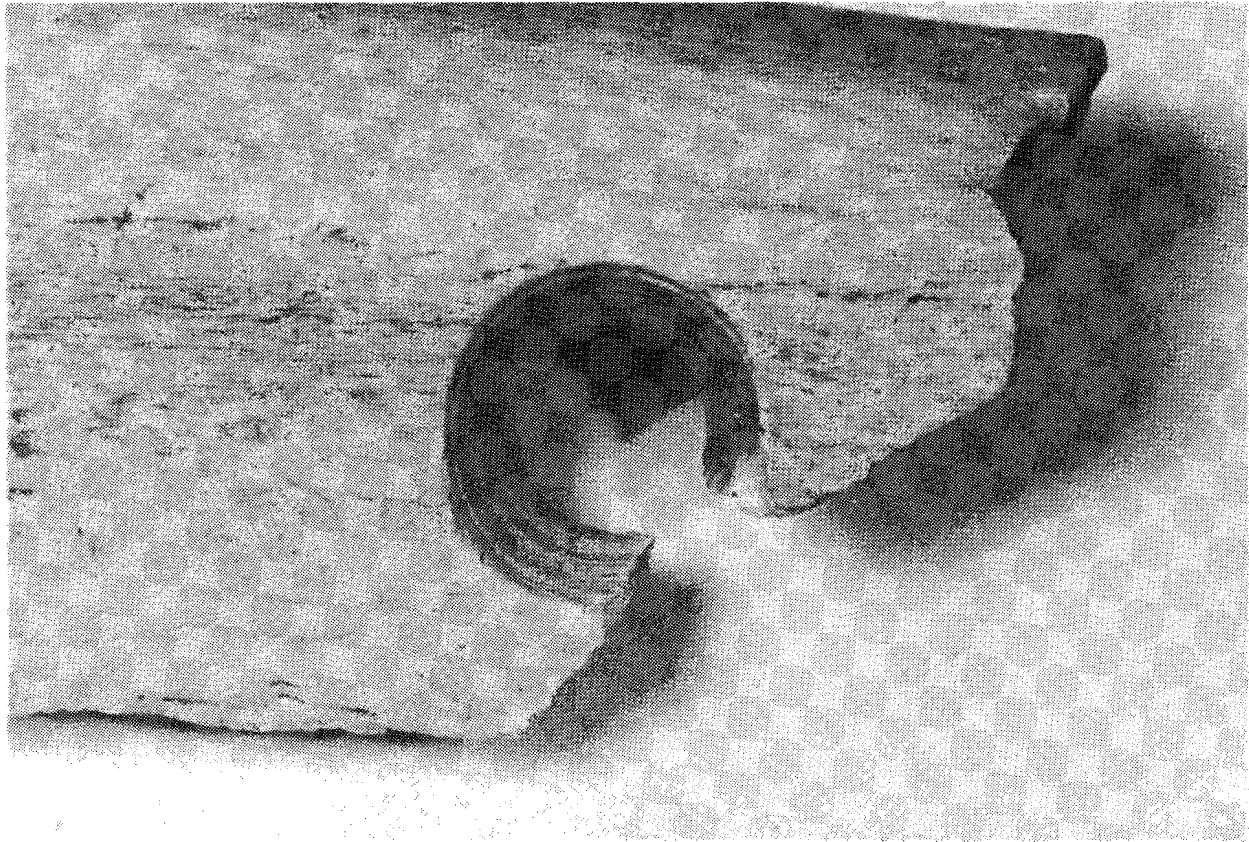

fig. 1 perforación rápida

Lam.XXVI

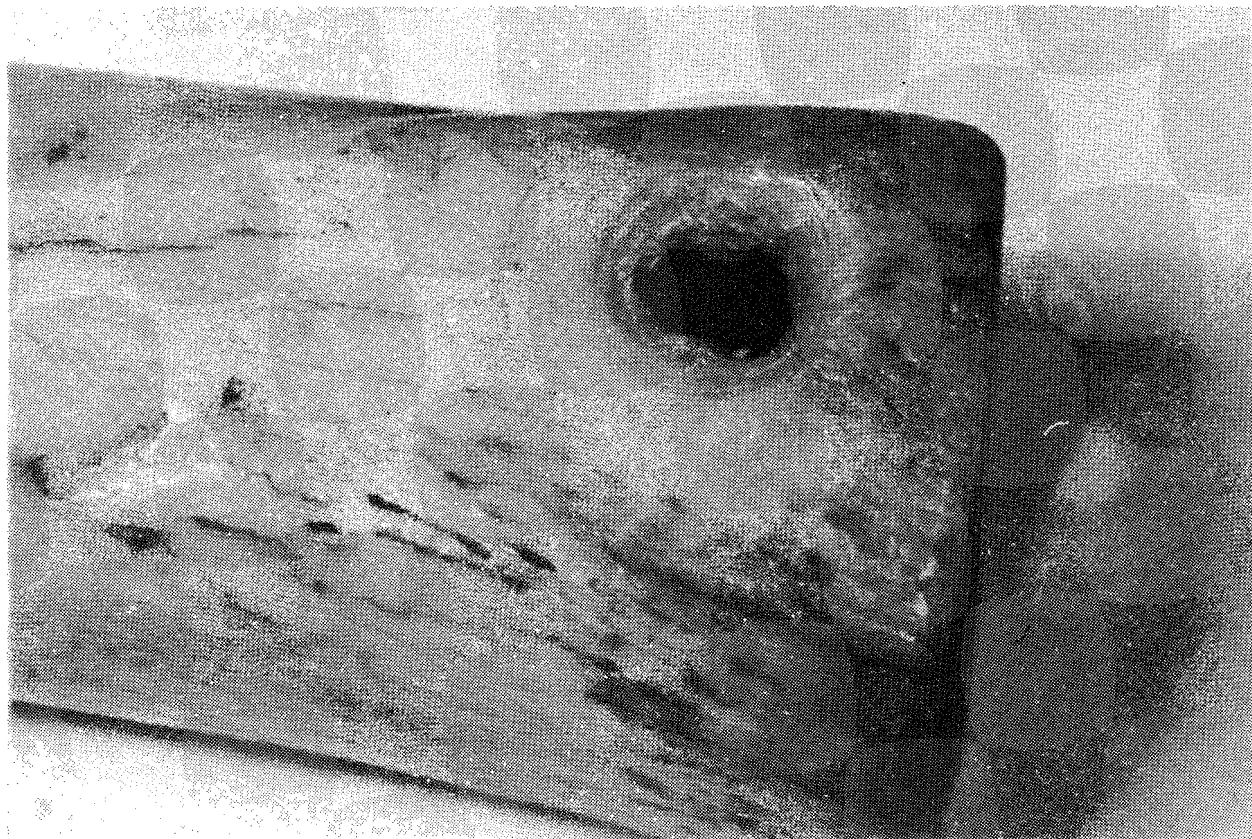

fig. 2 perforación irregular

G. Metal de la época española

Lam. XXVII

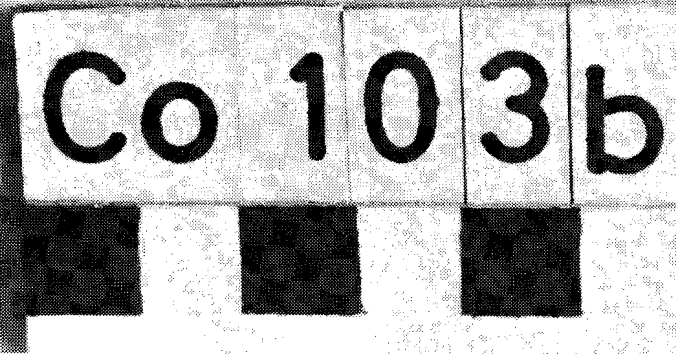

fig. 1 aguja de bronce (del tiempo colonial?)



fig. 2 aguja de bronce con motivo de gallo (del tiempo colonial?)

PLANOS

INDICE DE PLANOS

PROYECTO DE OBRAS DE RECONSTRUCCIÓN

Plano 1	Plan de orientación de la excavación Cochasquí.
Plano 2	<u>Montículo x</u> , plan de ubicación de los cortes.
Plano 3	Montículo x, corte 1, perfil N/O 1
Plano 4	Montículo x, corte 3, perfil este 1 visto desde el oeste, perfil sur 1 visto desde el norte, plan de perfil del molde y de las plataformas
Plano 5	Montículo x, corte 4, perfil grande de S/O con corte 4, ampliación no dibujada
Plano 6	<u>Montículo H</u> , perfil N/S desde 0
Plano 7	Montículo x, plan debajo de terraplén el montículo y de una capa de arena fuerte de 12 -- 35 cms, de altura 2917,10 en el norte hasta 2914,92 en el sur del corte
Plano 8	<u>Montículo a</u> , perfil N/S de 0
Plano 9	Montículo a, corte 1, plan 3 a
Plano 10	<u>Montículo n</u> , perfil del N/O hacia S/W











Plano 11	<u>Pueblo</u> plan de los 31 cortes
Plano 12	<u>Pueblo</u> , perfil O/W visto desde el sur (en S 16 m) Cortes 22 – 25, perfiles y planes
Plano 13	Pueblo perfil N/S G visto desde el este (en W 2 m), cortes 1, 2, 4, 5, 6, perfiles y planes.
Plano 14	perfil N/S 14 visto desde el este (en 12 m.), cortes 20, 21, 23, 31, perfiles y planes.
Plano 15	Pueblo, perfil O/W 3 hasta S 5 m 3 a hasta S 6 m 3 b hasta 6,50 m visto desde el sur, perfil y plan
Plano 16	<u>Pirámide E</u> , corte O/W N 13, vista y pared norte
Plano 17	Pirámide E, plan de las plataformas
Plano 18	<u>Pirámide L</u> , corte O/W grande, pared norte,
Plano 19	Pirámide L, corte O/W grande, pared norte plano en altura de las capas (Plan)
Plano 20	<u>Pirámide G</u> , construcción de muro de cangagua del terraplén sur
Plano 21	Pirámide G, canal (molde)
Plano 22	<u>Pirámide H</u> , restos de un conjunto de moldes, plan y perfil
Plano 23	al este de la <u>Pirámide C</u> , restos de un conjunto de

moldes, plan y perfil

Plano 24

Ajambi, perfil pared este —
corte estratigráfico / artificial

Plan 1 Plan de orientación de la excavación Cochachqui
COCHASQUI

-  pirámides
-  montículos funerarios
-  montículos funerarios (sólo visibles en fotografías aéreas)
-  ubicación de cortes
-  hallazgos aislados (con numeración)
-  zanjas (abiertas en 1954/55)
-  linderos de lotes
-  quebradas (casi siempre secas)
-  caminos carrozables
-  LAS TOLAS denominación de llanos
-  edificios

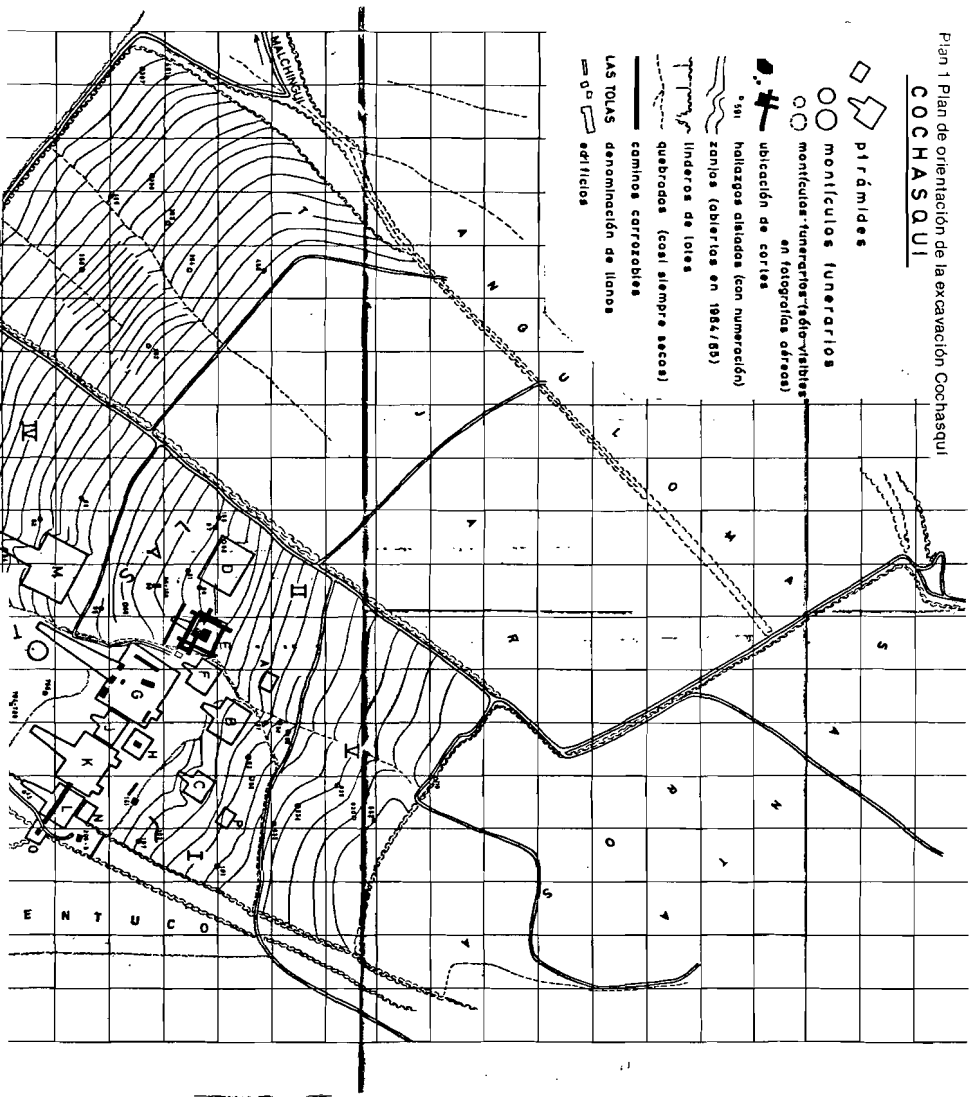

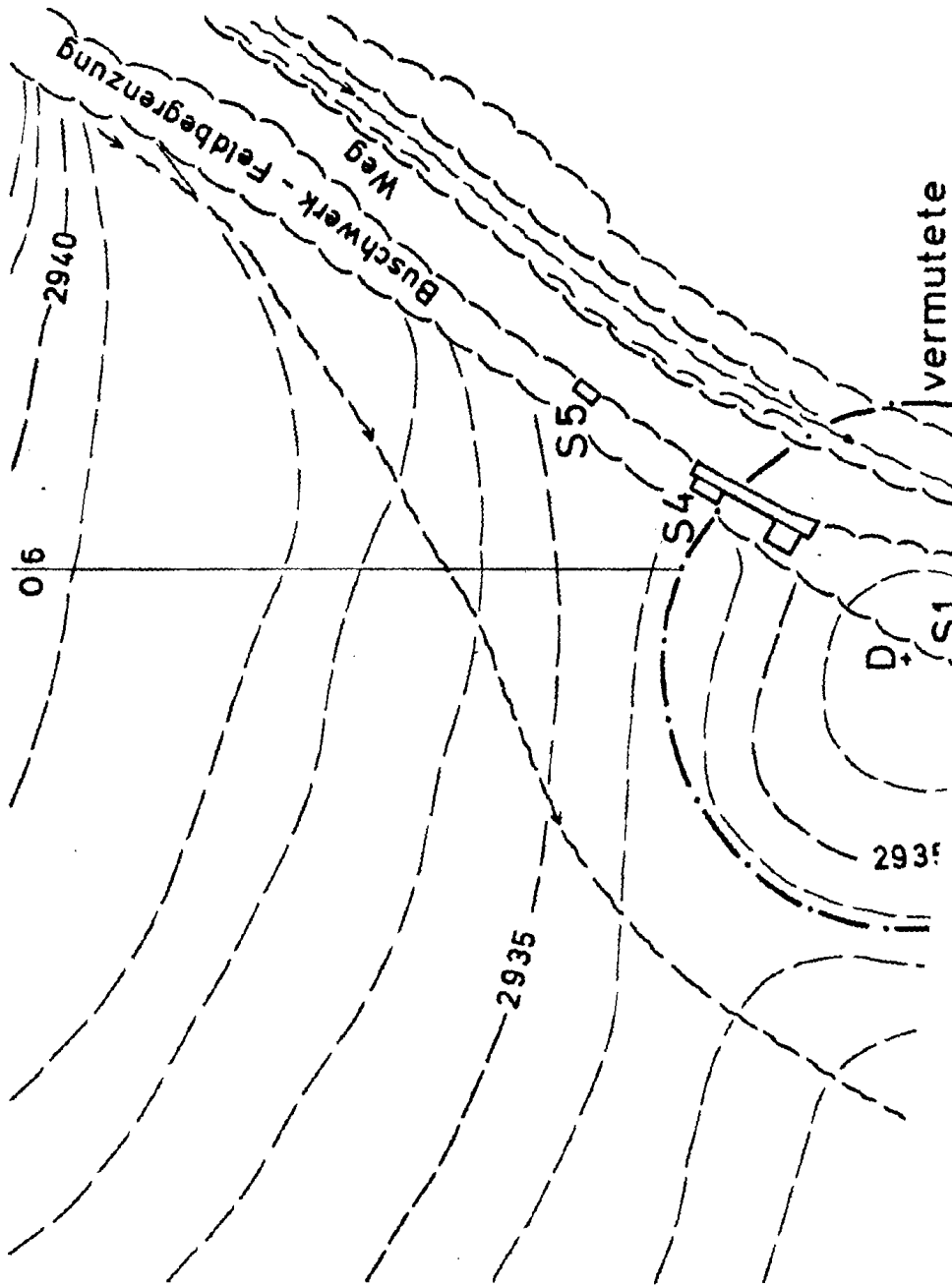

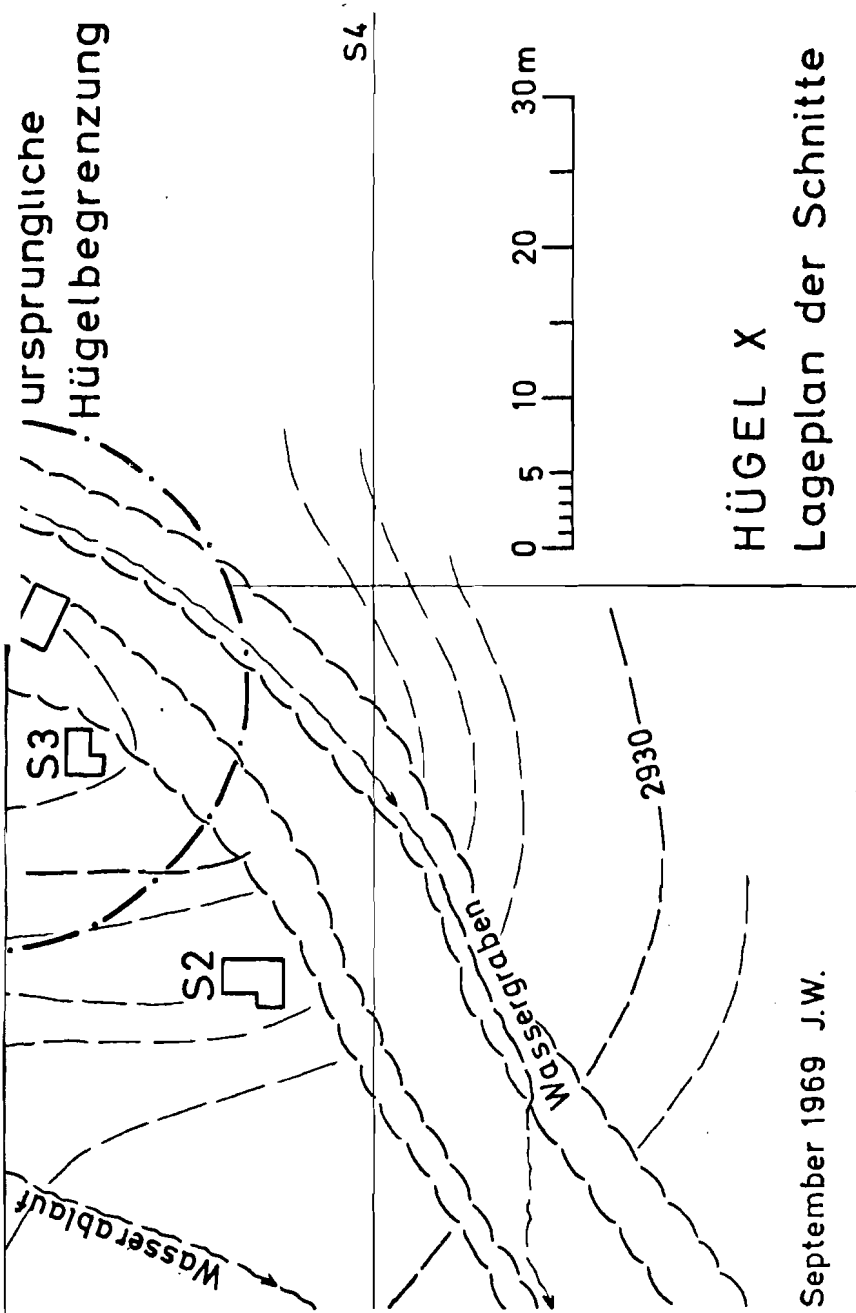

September 1969 J.W.

Plan 2 Montículo x, plan de ubicación de los cortes.

IN 3.66
| O 2.18

IN 3.98
| O 3.12

IN 4.30
| O 4.06

IN 4.62
| O 5.00

HÜGEL X, SCHNITT 1, PROFIL 1

6 m

M. 1:20





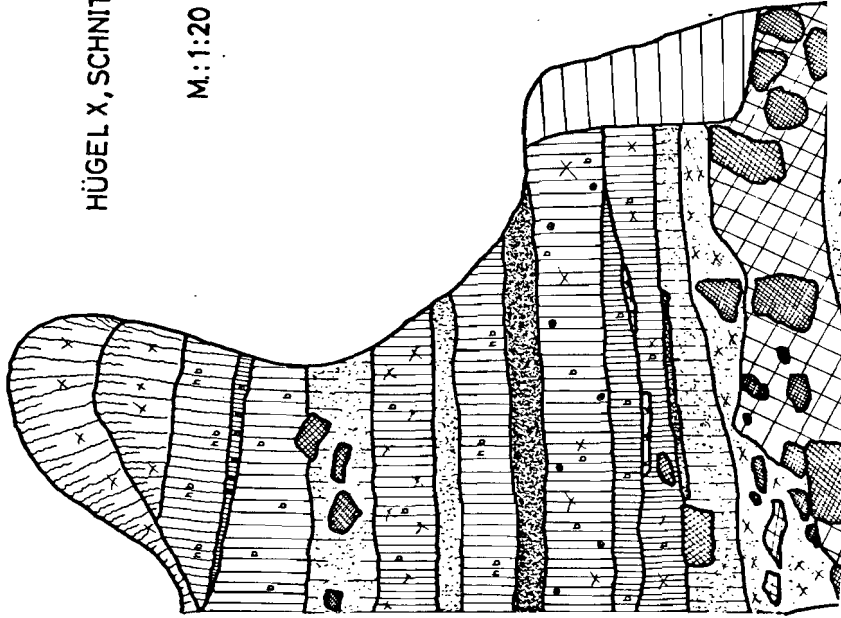

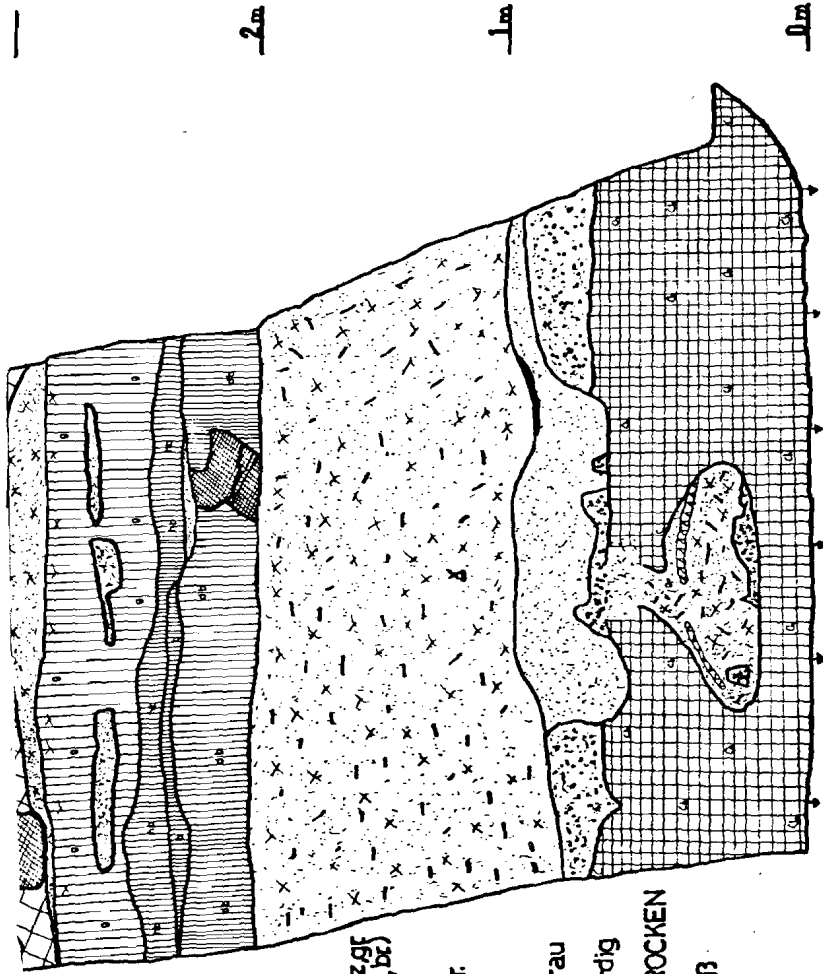







5 m

4 m





LEGENDE

-  HUMUS
-  STÖRUNG
-  LEHM (schwarzgf
hellbr, dunkelbr, br)
-  KALK
-  LEHM/SAND, br.
-  SAND, grau
-  SAND, dunkelgrau
-  CANGAGUA, erdig
-  CANGAGUA BROCKEN
-  SAND, grauweiß
-  TON, weiß
-  SCHERBEN
-  OBSIDIAN
-  HOLZKOHLE
-  CHOCOTO, anstehend

Plan 3 Monticulo x, corte 1, perfil N/O 1.

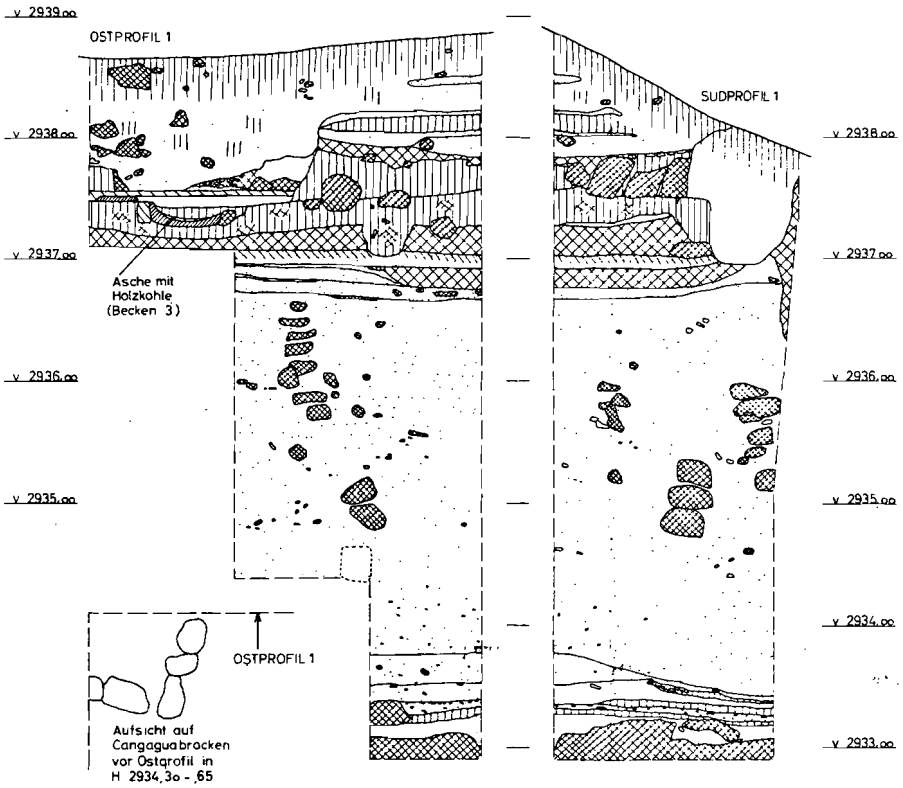

Plan 4 Monticulo x, co desde el norte. plan de g

TOLAS III HÜGEL X Schnitt 3

FIL 1 von Westen gesehen
 FIL 1 von Norden gesehen

PLAN: und PROFIL der Becken und Plattformen

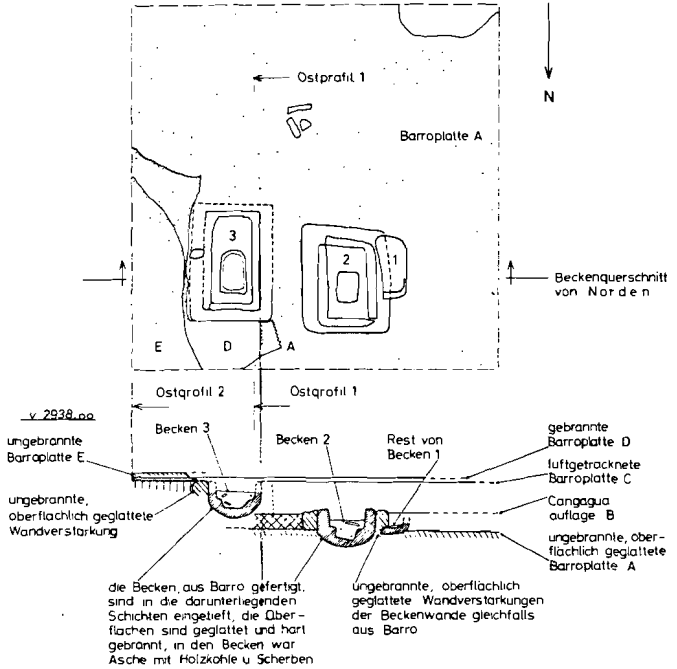

Legende:

- Grabungsgrenze
- Humus, graubrauner erdiger Sand
- grauer Sand
- Chacota, braun
- lehmiger Sand, braun
- Cangaguabrocken
- Cangagua, erdig
- Barro, luftgetrocknet
- Barro, gebrannt
- Barro, mit Sand
- Sand mit Chacota
- Brandschicht mit Scherben
- Cangagua, anstehend

Maßstab 1:20

1m 2m

Schasqui den 15. Dez 1964 J.W.
 te 3, perfil este 1 visto desde el oeste, perfil sur 1 visto
 perfil del molde y de las plataformas.

HÜGEL X, großes Profil von Südosten
mit Schnitt 4

Legende:

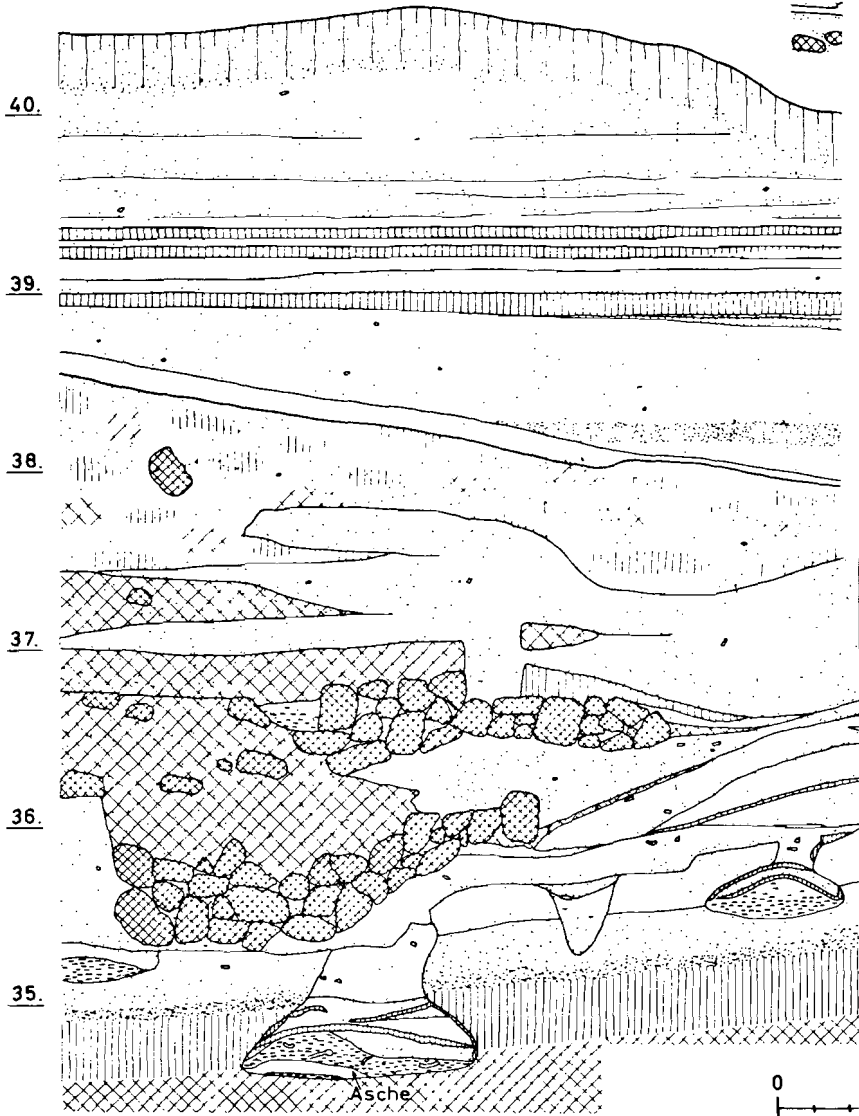
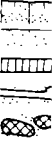

Plan 5 Montículo x, corte 4, perfil grande de S/O con corte 4, ampliación no dibujada.

- ▨ humöser Sand
- ▨ grauer Sand
- ▨ Lehmband, hell
- ▨ Bimslage, weiß
- ⊗ Cangaguabrocken

- ▨ Cang., erdig
- ▨ Holzkohle
- ▨ Schnecken
- ▨ lehmiger S.
- ▨ dunkelgrauer S.

- ▨ Chocoto, anstehend
- ▨ Cangagua, anstehend
- ▨ Beckenboden oberflächlich gebrannt, anschließende Lehmplatte luftgetrocknet

Schnitt 4

▼ 2940.00

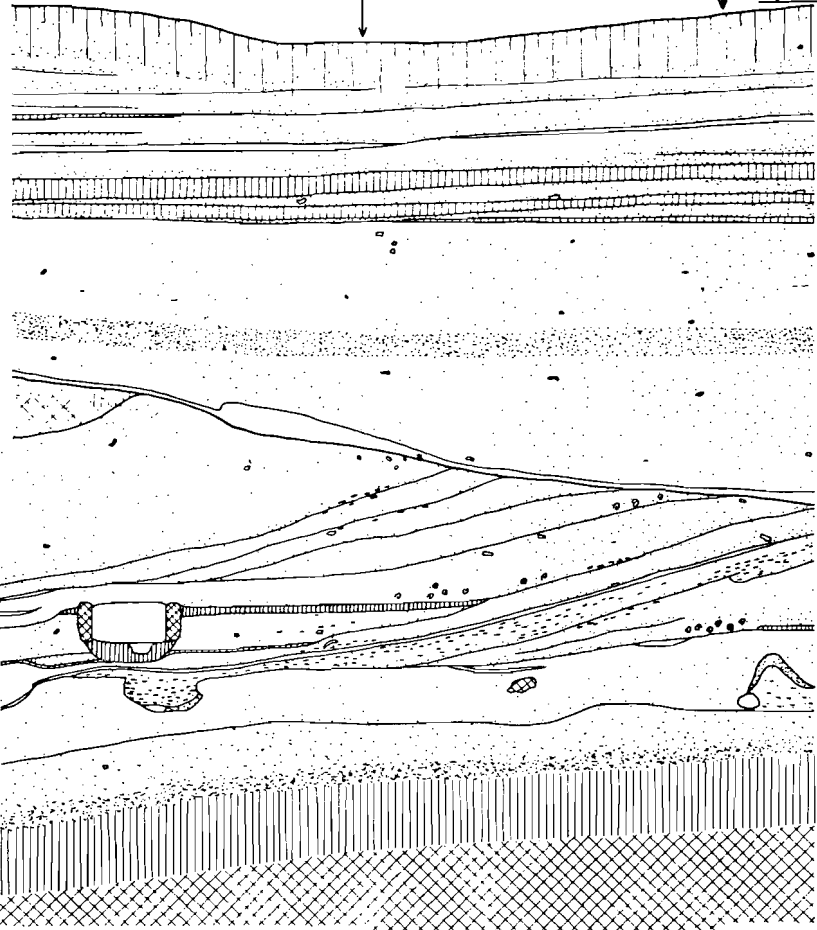

39.

38.

37.

36.

35.

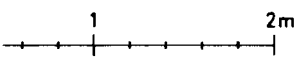

Mai 1965 J.W.

HÜGEL h, Nordsüdprofil von Osten

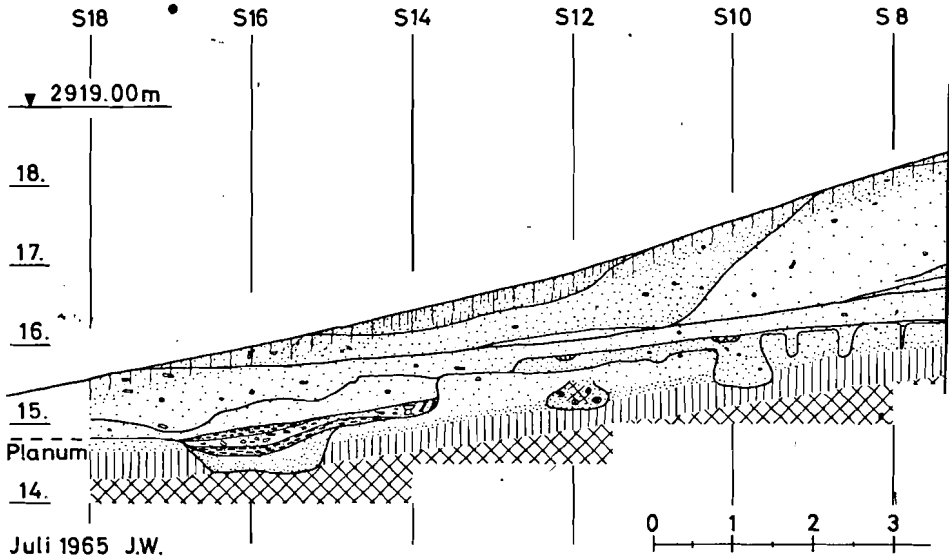

Plan 6 Monticulo H, perf

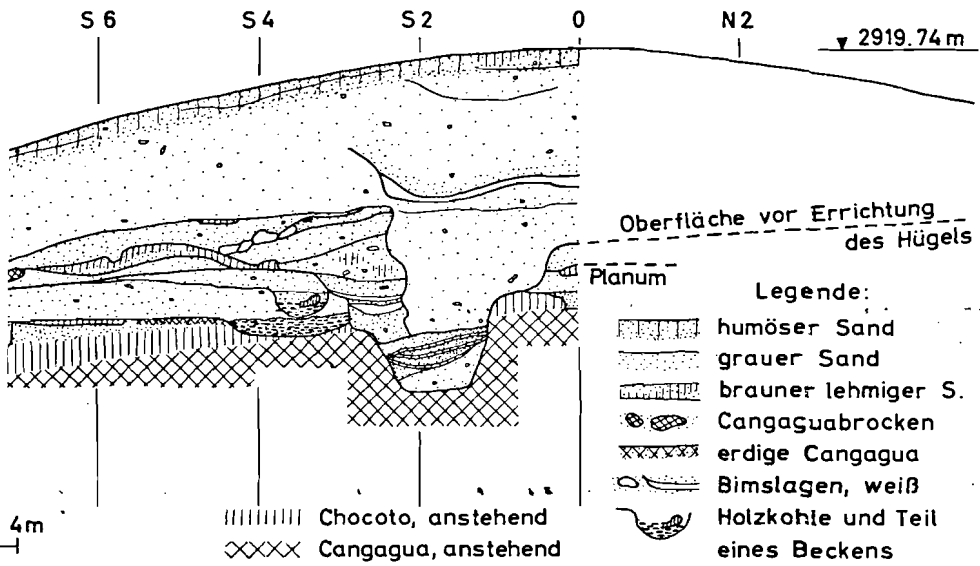

N/S desde O.

Plan 7 **Montículo H**, plan debajo de terraplén el montículo y de una capa de arena fuerte de 12-35 cm de altura 2917,10 en el norte hasta 2914,92 en el sur del corte.

HÜGEL h, Planum unter Hügelanschüttung und einer 12-35 cm von Höhe 2917.10 im Norden bis 2914.92 im Süden

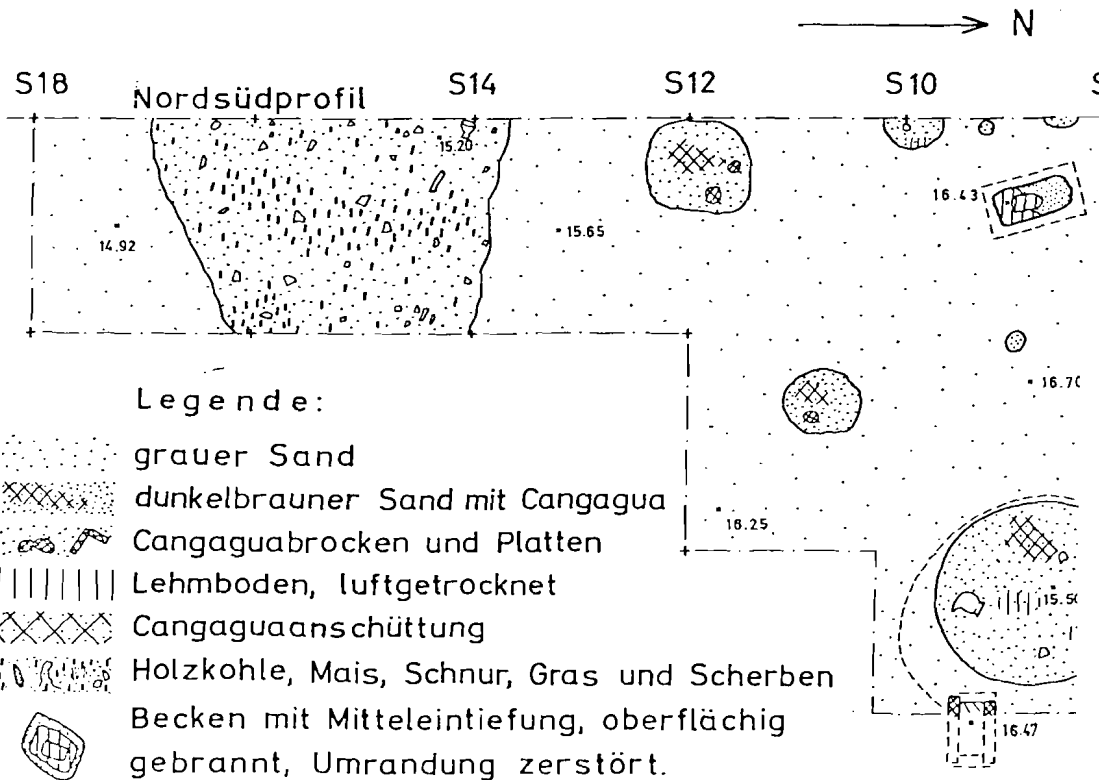

n starken Sandschicht,
h des Schnittes.

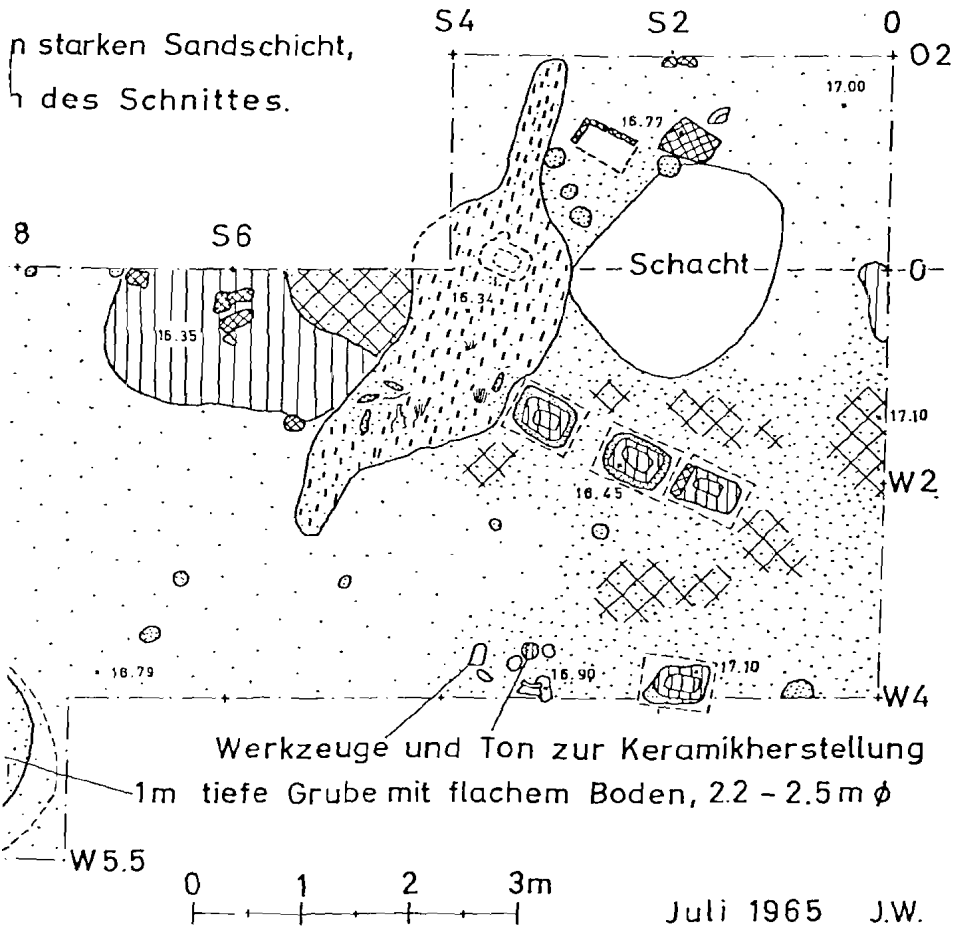

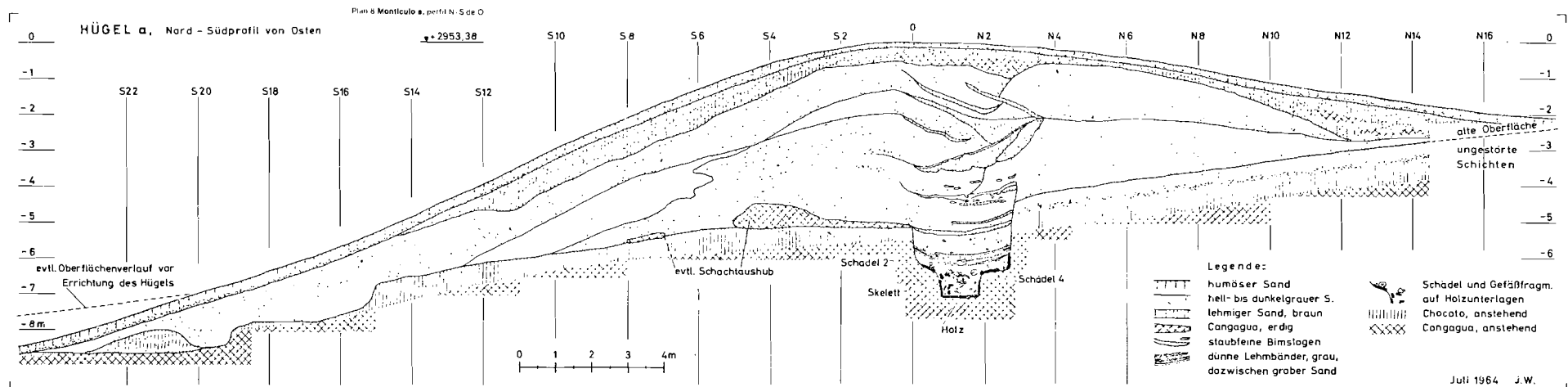

HÜGEL a, Schnitt 1, Planum 3a, M.:1:20

Plan 9 Monticulo a, corte 1, plan 3a.

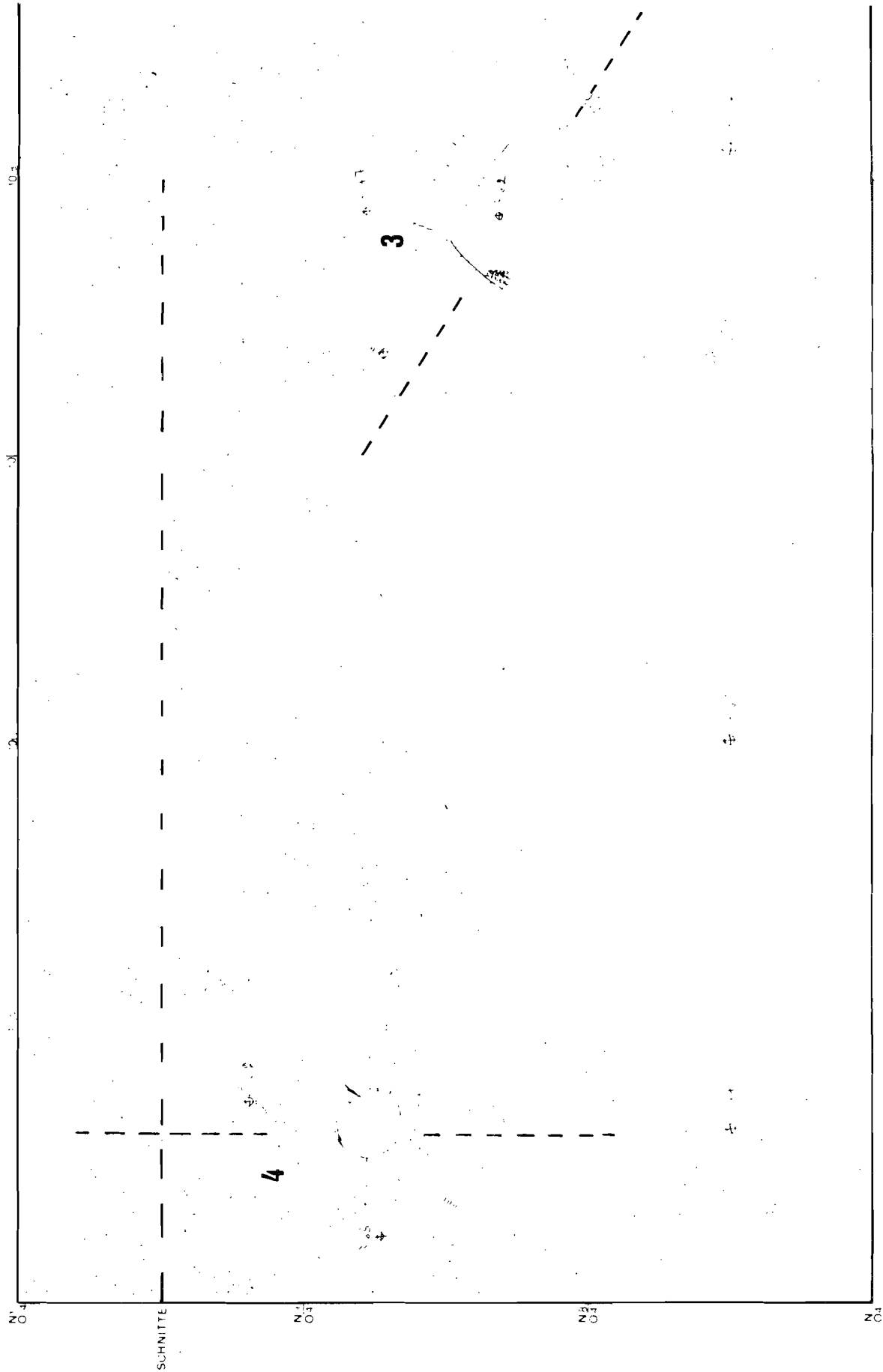

Plan 10 Montículo n, perfil del N/O hacia S/W.

HÜGEL n, PROFIL von Nordost nach Südwest verlaufend

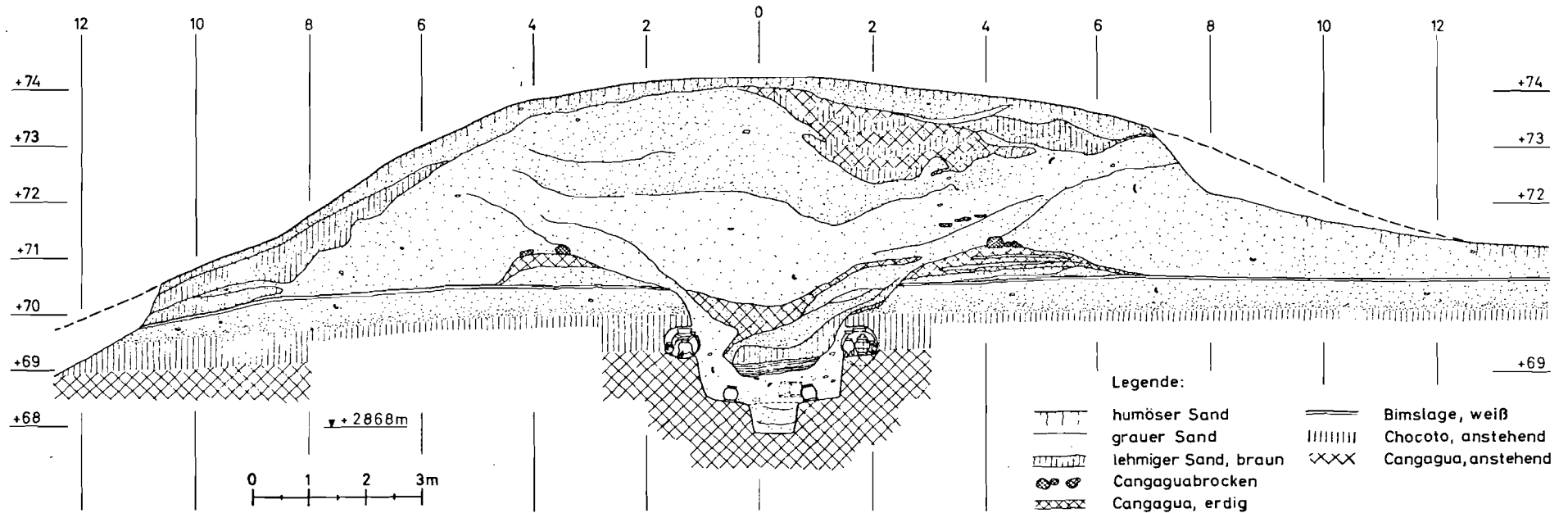

Januar 1965 J.W.

Plan 11 Pueblo, plan de los 31 cortes.
SIEDLUNG, Planum der 31 Schnitte (etwas schematisch)

W-D
S 3003 71

Marz - Oktober 1964 R.H. + J.W.

+S0
+S1
Legende:

- +S2 Grabungsgrenzen
- +S3 absolute Höhen
- +S4 Störung teils bis 85cm unter Oberfläche
- +S5 Chocotokante bis zu der, meist von Süden her, Chocoto abgraben ist auf Chocotokante oder -sockel aufgelegte Cangaguabrocken
- +S6 Cangaguamauer, 2-3 Lagen
- +S7 Skelette zwischen Cangaguabrocken ein unvollständiges Skelett, Schn. 17
- +S8 Feuerstelle im Schnitt 2, 28, 1m und 1,80m unter Oberfläche
- +S9 Brandschichten im Schnitt 3, 18, 20, 21, etwa 1m bis 1,25m unter Ob.
- +S10 Scherbenschichten

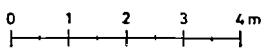
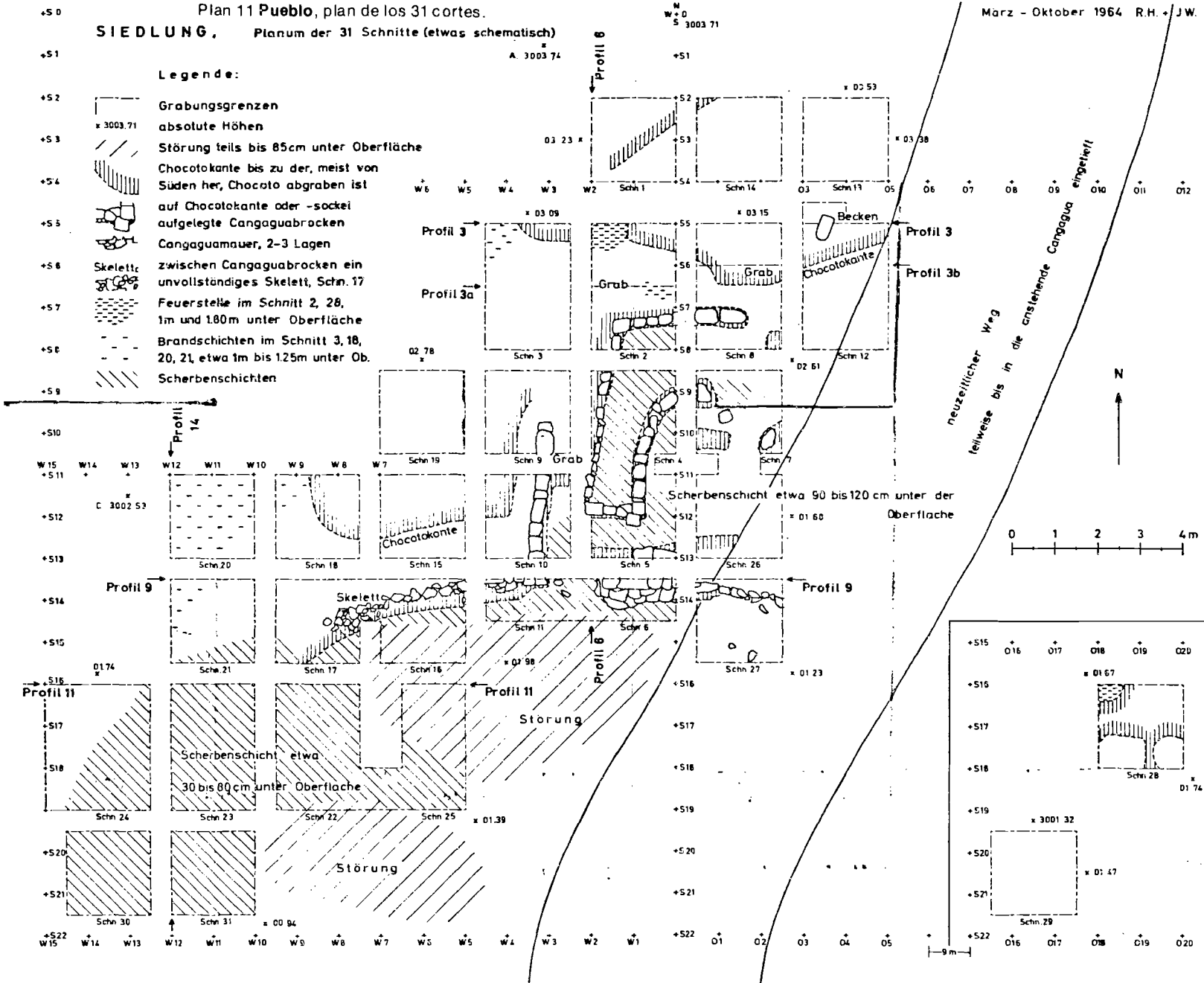

neuzzeitlicher Weg teilweise bis in die existierende Cangagua eingetieft

9 m

SIEDLUNG, Ostwestprofil 11 von Süden gesehen (bei S 16 m)

Plan 12 Pueblo, perfil O/W visto desde el sur (en S 16 m), cortes 22-25, perfiles y planes.

02

Schnitt 24

Schnitt 23

Schnitt 22

3002.00 m

Schnitt 25

02

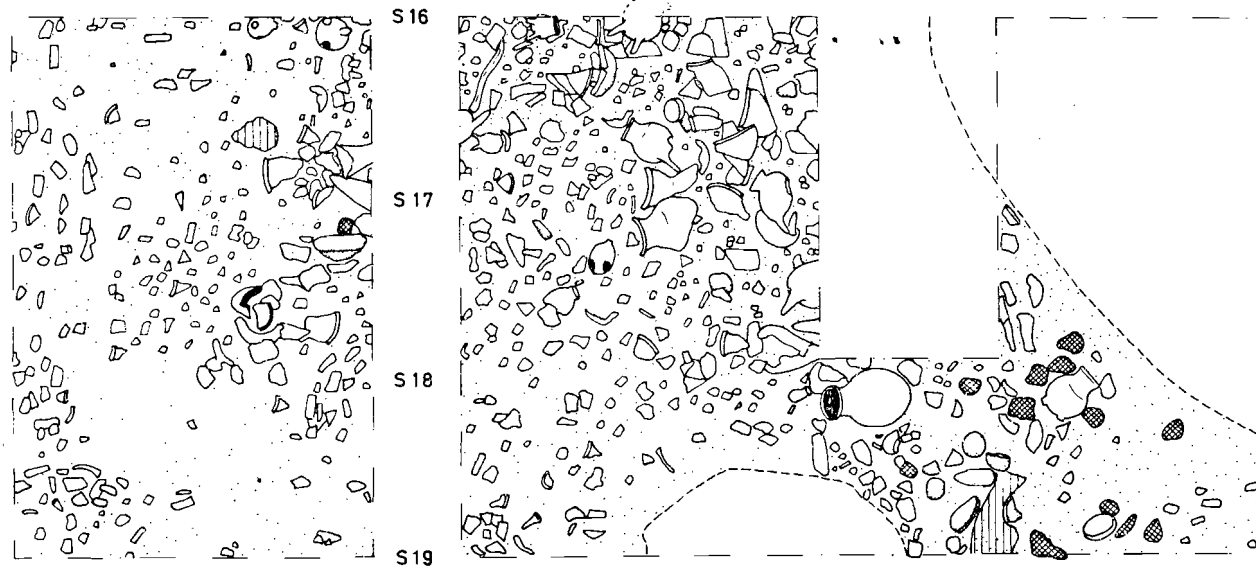
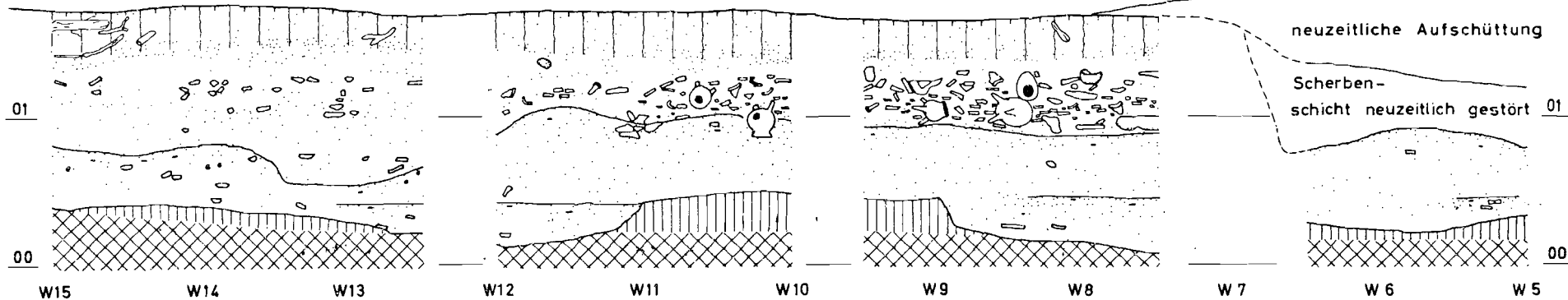

Plan 13 Pueblo, perfil N/S G visto desde el este (en W 2 m), cortes 1, 2, 4, 5, 6, perfúes y planes.

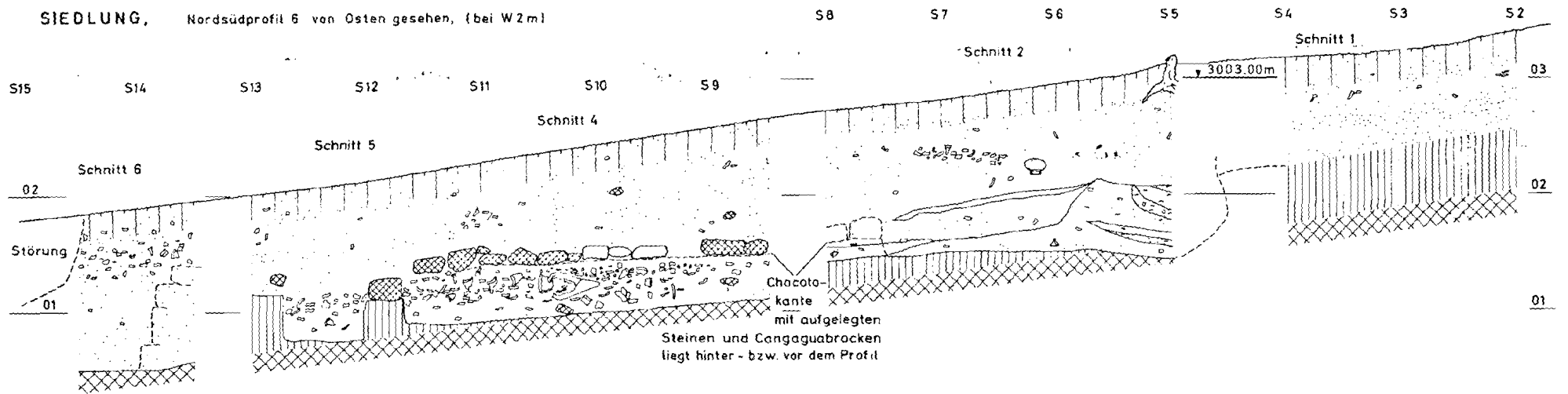

Plan 14 Pueblo, perfil N/S 14 visto desde el este (en W 12 m), cortes 20, 21, 23, 31, perfiles y planes.

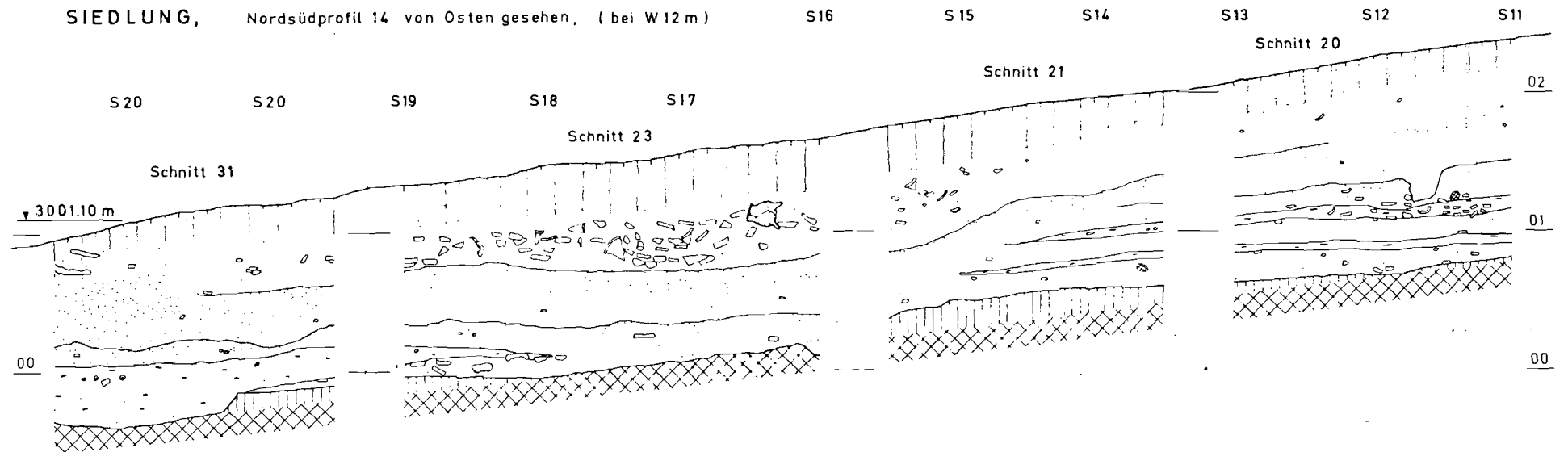

Plan 15 Pueblo, perfil O/W 3 hasta S 5 m.; 3 a hasta S 6 m., 3 b hasta 6,50 m.;
visto desde el sur, perfil y plan.

SIEDLUNG. Ostwestprofile 3 bei S 5; 3a bei S 6; 3b bei S 6.50m von Süden gesehen und Plana

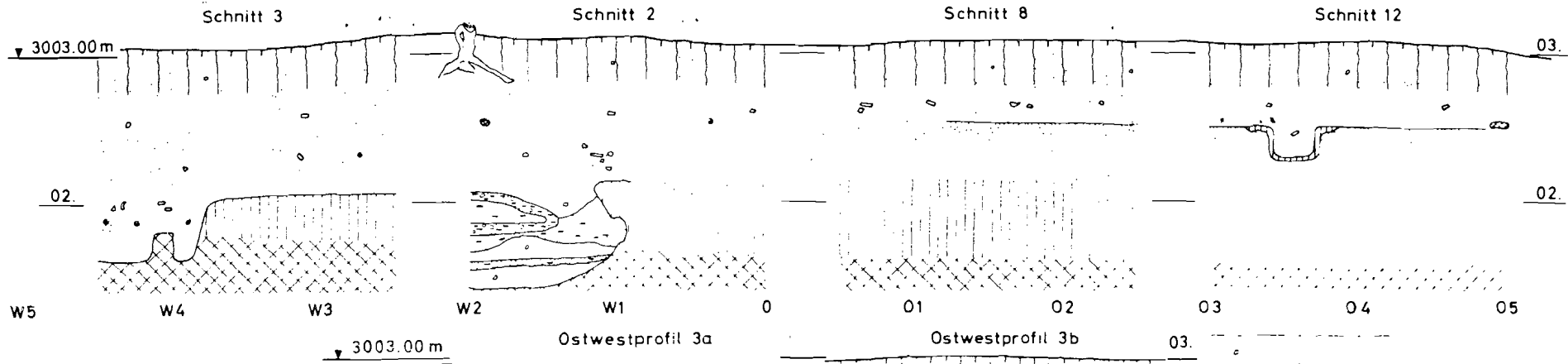

Legende:



- graubrauner humöser Sand
- grauer Sand mit Scherben
- dunkelgrau mit Schnecken
- Asche mit etwas Holzkohle
- Brandschicht mit Bimsbröckchen
- Becken aus Chocoto, oberflächlich geglättet, luftgetrocknet
- Chocoto, anstehend, dunkelbraun
- Cangagua, anstehend, braun

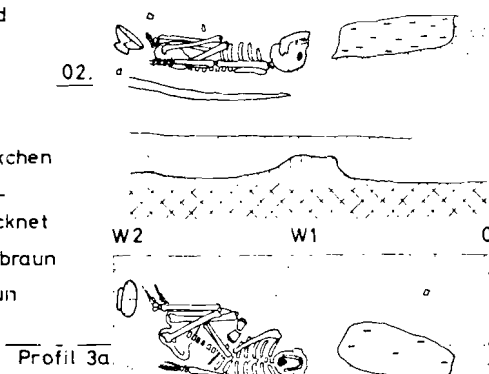

Planum bei 65 bis 85cm unter Oberfläche

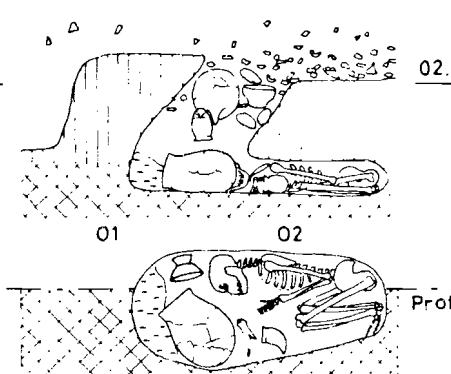

Planum bei 140 bis 155cm unter Oberfläche

März - April 1964

J.W.

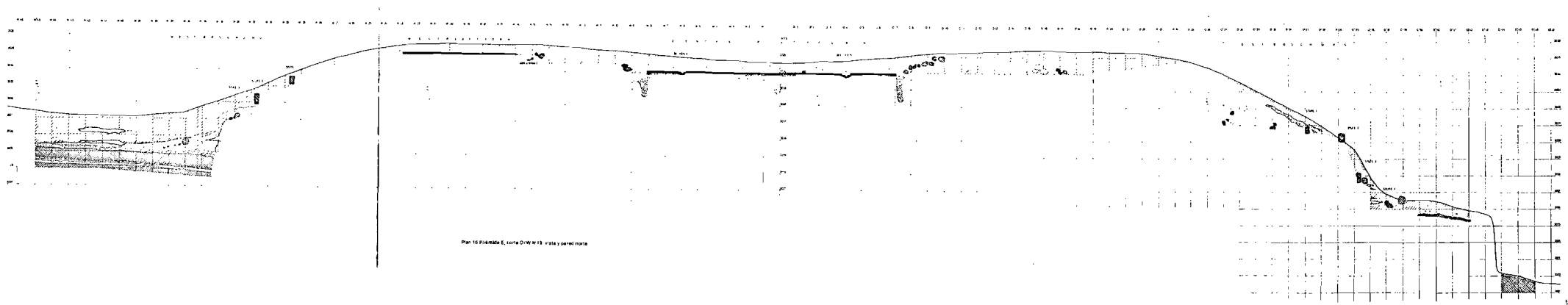

Plan 10 PIANI E, corso D'W M 13 vista perpendicolare

Plan 17 Pirámide E. plan de las plataformas.

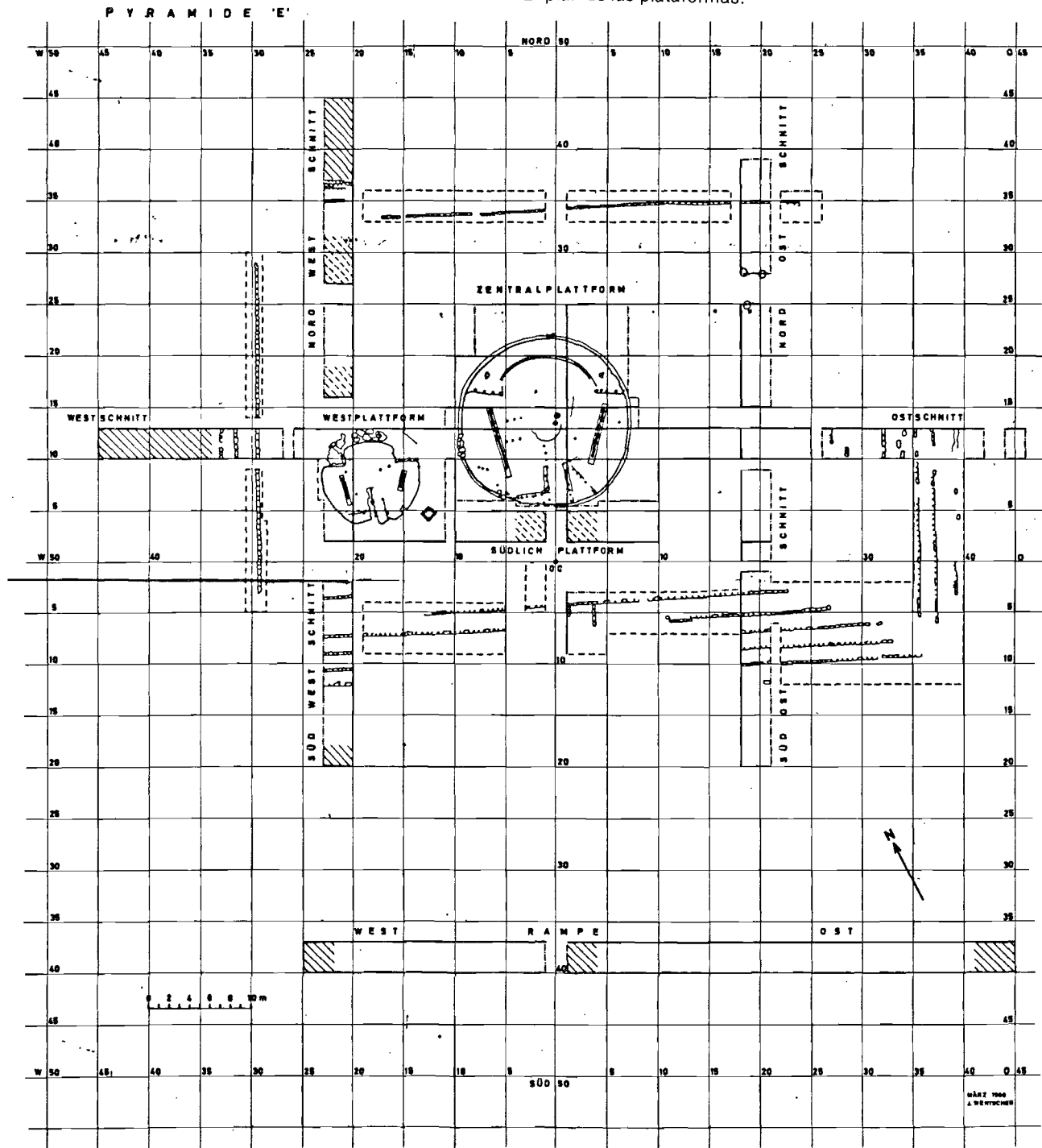

Plan 18 Pirâmide L, corte O/W grande, pared norte.

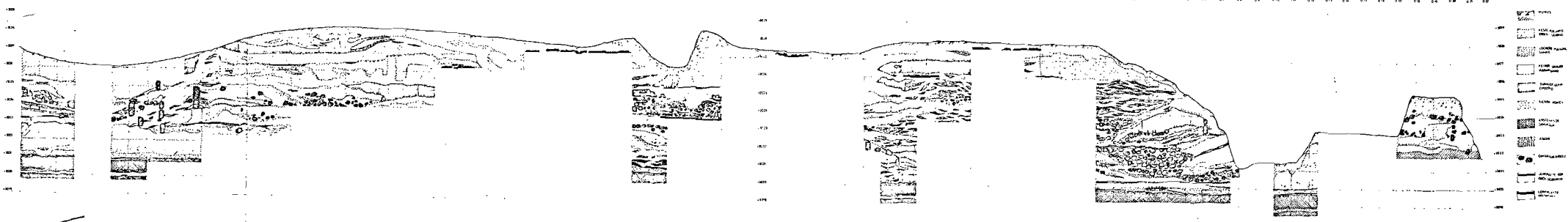

- 1. PIEDRA DE CALIZA
- 2. PIEDRA DE CALIZA
- 3. PIEDRA DE CALIZA
- 4. PIEDRA DE CALIZA
- 5. PIEDRA DE CALIZA
- 6. PIEDRA DE CALIZA
- 7. PIEDRA DE CALIZA
- 8. PIEDRA DE CALIZA
- 9. PIEDRA DE CALIZA
- 10. PIEDRA DE CALIZA
- 11. PIEDRA DE CALIZA
- 12. PIEDRA DE CALIZA
- 13. PIEDRA DE CALIZA
- 14. PIEDRA DE CALIZA
- 15. PIEDRA DE CALIZA
- 16. PIEDRA DE CALIZA
- 17. PIEDRA DE CALIZA
- 18. PIEDRA DE CALIZA
- 19. PIEDRA DE CALIZA
- 20. PIEDRA DE CALIZA
- 21. PIEDRA DE CALIZA
- 22. PIEDRA DE CALIZA
- 23. PIEDRA DE CALIZA
- 24. PIEDRA DE CALIZA
- 25. PIEDRA DE CALIZA
- 26. PIEDRA DE CALIZA
- 27. PIEDRA DE CALIZA
- 28. PIEDRA DE CALIZA
- 29. PIEDRA DE CALIZA
- 30. PIEDRA DE CALIZA
- 31. PIEDRA DE CALIZA
- 32. PIEDRA DE CALIZA
- 33. PIEDRA DE CALIZA
- 34. PIEDRA DE CALIZA
- 35. PIEDRA DE CALIZA
- 36. PIEDRA DE CALIZA
- 37. PIEDRA DE CALIZA
- 38. PIEDRA DE CALIZA
- 39. PIEDRA DE CALIZA
- 40. PIEDRA DE CALIZA
- 41. PIEDRA DE CALIZA
- 42. PIEDRA DE CALIZA
- 43. PIEDRA DE CALIZA
- 44. PIEDRA DE CALIZA
- 45. PIEDRA DE CALIZA
- 46. PIEDRA DE CALIZA
- 47. PIEDRA DE CALIZA
- 48. PIEDRA DE CALIZA
- 49. PIEDRA DE CALIZA
- 50. PIEDRA DE CALIZA
- 51. PIEDRA DE CALIZA
- 52. PIEDRA DE CALIZA
- 53. PIEDRA DE CALIZA
- 54. PIEDRA DE CALIZA
- 55. PIEDRA DE CALIZA
- 56. PIEDRA DE CALIZA
- 57. PIEDRA DE CALIZA
- 58. PIEDRA DE CALIZA
- 59. PIEDRA DE CALIZA
- 60. PIEDRA DE CALIZA
- 61. PIEDRA DE CALIZA
- 62. PIEDRA DE CALIZA
- 63. PIEDRA DE CALIZA
- 64. PIEDRA DE CALIZA
- 65. PIEDRA DE CALIZA
- 66. PIEDRA DE CALIZA
- 67. PIEDRA DE CALIZA
- 68. PIEDRA DE CALIZA
- 69. PIEDRA DE CALIZA
- 70. PIEDRA DE CALIZA
- 71. PIEDRA DE CALIZA
- 72. PIEDRA DE CALIZA
- 73. PIEDRA DE CALIZA
- 74. PIEDRA DE CALIZA
- 75. PIEDRA DE CALIZA
- 76. PIEDRA DE CALIZA
- 77. PIEDRA DE CALIZA
- 78. PIEDRA DE CALIZA
- 79. PIEDRA DE CALIZA
- 80. PIEDRA DE CALIZA
- 81. PIEDRA DE CALIZA
- 82. PIEDRA DE CALIZA
- 83. PIEDRA DE CALIZA
- 84. PIEDRA DE CALIZA
- 85. PIEDRA DE CALIZA
- 86. PIEDRA DE CALIZA
- 87. PIEDRA DE CALIZA
- 88. PIEDRA DE CALIZA
- 89. PIEDRA DE CALIZA
- 90. PIEDRA DE CALIZA
- 91. PIEDRA DE CALIZA
- 92. PIEDRA DE CALIZA
- 93. PIEDRA DE CALIZA
- 94. PIEDRA DE CALIZA
- 95. PIEDRA DE CALIZA
- 96. PIEDRA DE CALIZA
- 97. PIEDRA DE CALIZA
- 98. PIEDRA DE CALIZA
- 99. PIEDRA DE CALIZA
- 100. PIEDRA DE CALIZA

18d

Plan 19 Pirâmide L, corte O/W grande, pared norte plano en altura de las capas (Plan).

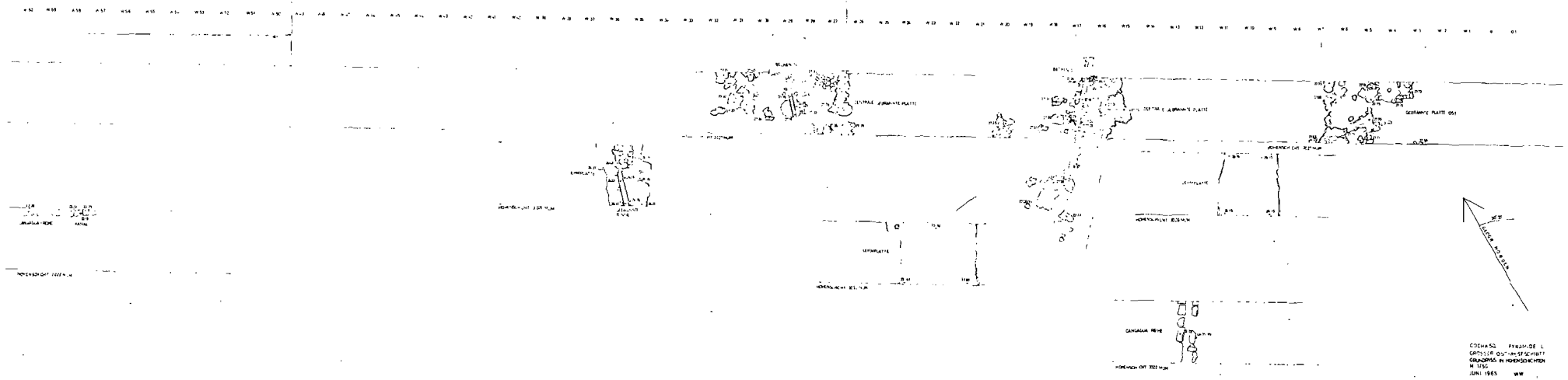

COCHASO FRESQUE L
 687336 00' ANSIC-1887
 GRANADA, M. HERRERA-1888
 M. 1155
 JUNI 1885. NW

Plan 20 Pirámide G, construcción de muro de cangagua del terraplén sur.

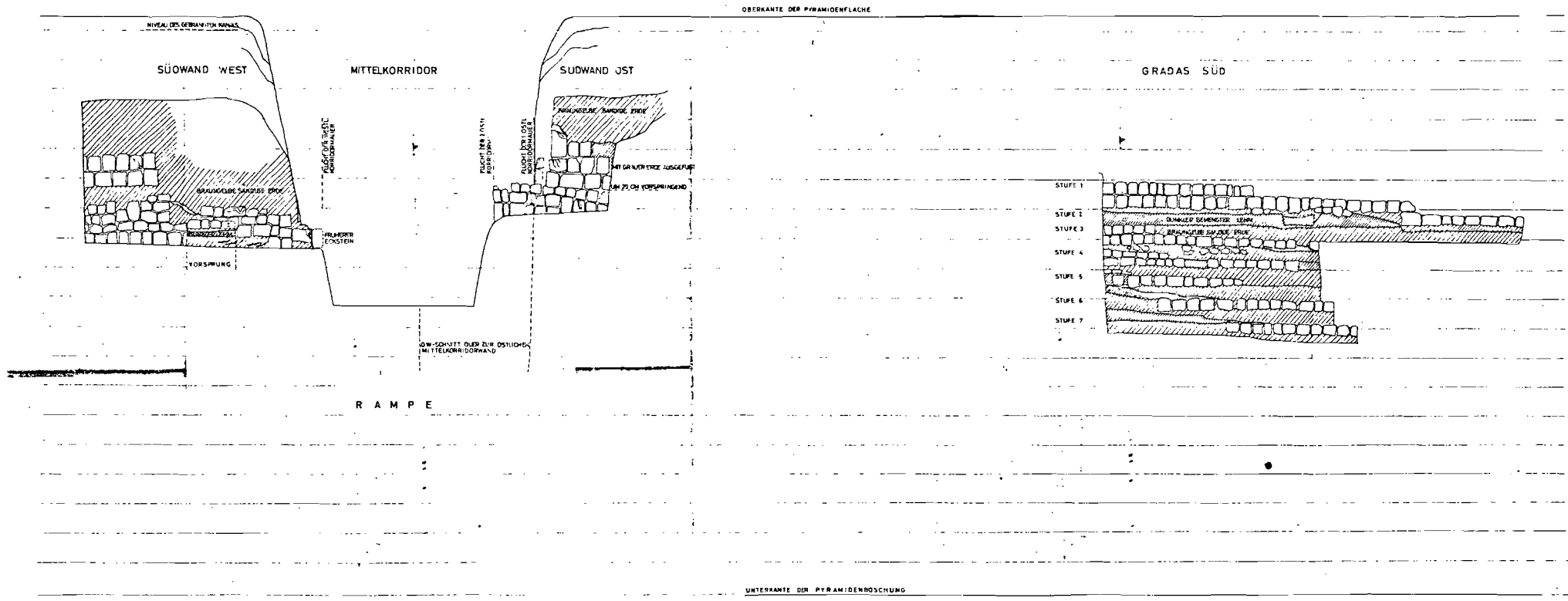

Plan 21 Pyramide G, canal (molde)

RINNENPROFILE

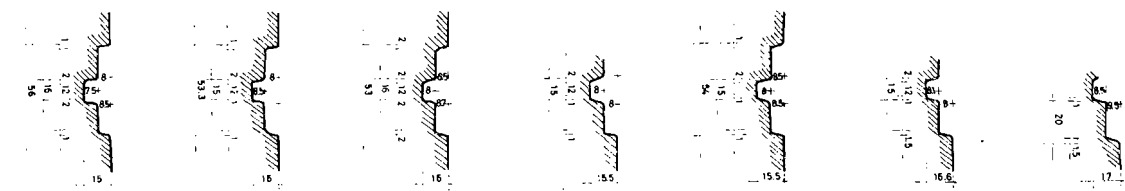

SCHNITT BB

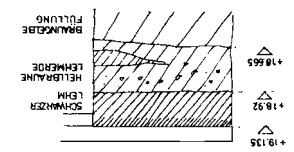

UK BETTUNG \triangle +19.65
 UK KANALKÖRPER \triangle +19.92
 OK KANALSCHULTER \triangle +19.135

OK KANALKÖRPER \triangle +19.09
 OK KANALSCHULE \triangle +18.865
 UK KANALKÖRPER \triangle +18.875
 UK BETTUNG \triangle +18.425

HEILBRÄUNLICHE LEHME MIT TONSCHERBEN UND BIMSTÜCKCHEN
 BRÄUNLICHE LEHME FÜLLUNGSSCHICHT

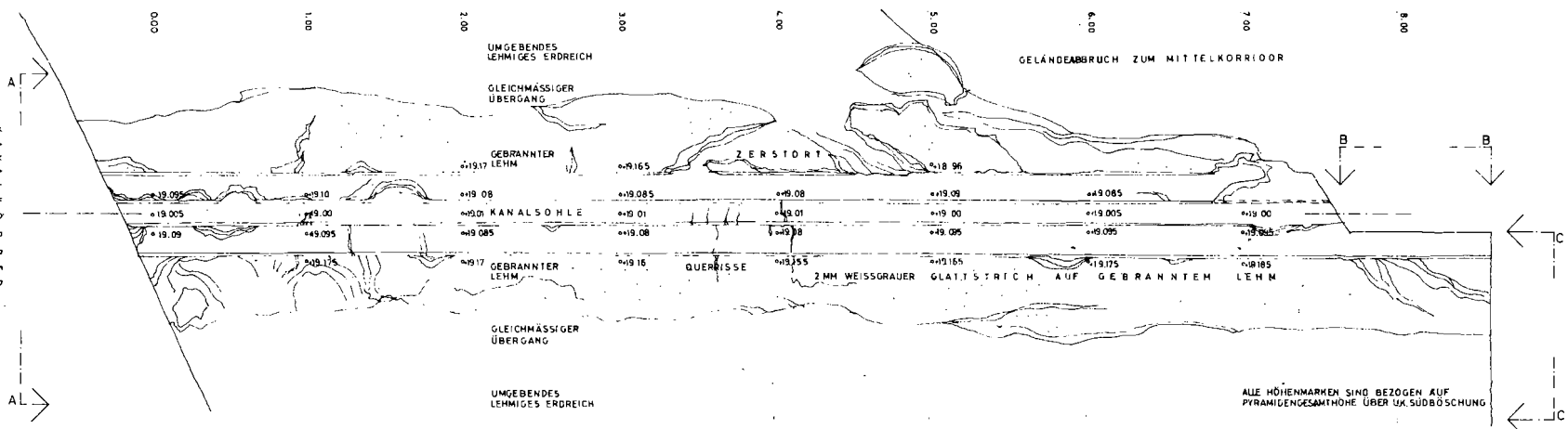

KANALGRUNDRISS

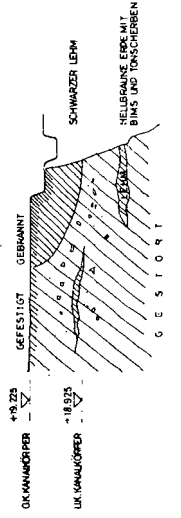
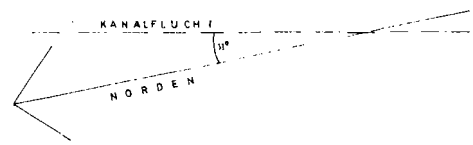

ALLE HÖHENMARKEN SIND BEZOGEN AUF PYRAMIDENGESAMTHÖHE ÜBER UK SÜDBÖSCHUNG

COCHASQUI - AUSGRABUNG
 PYRAMIDE G KANAL M 1/20
 7.5.64 WW

Plan 22 Pirámide H, restos de un conjunto de moldes, plan y perfil.

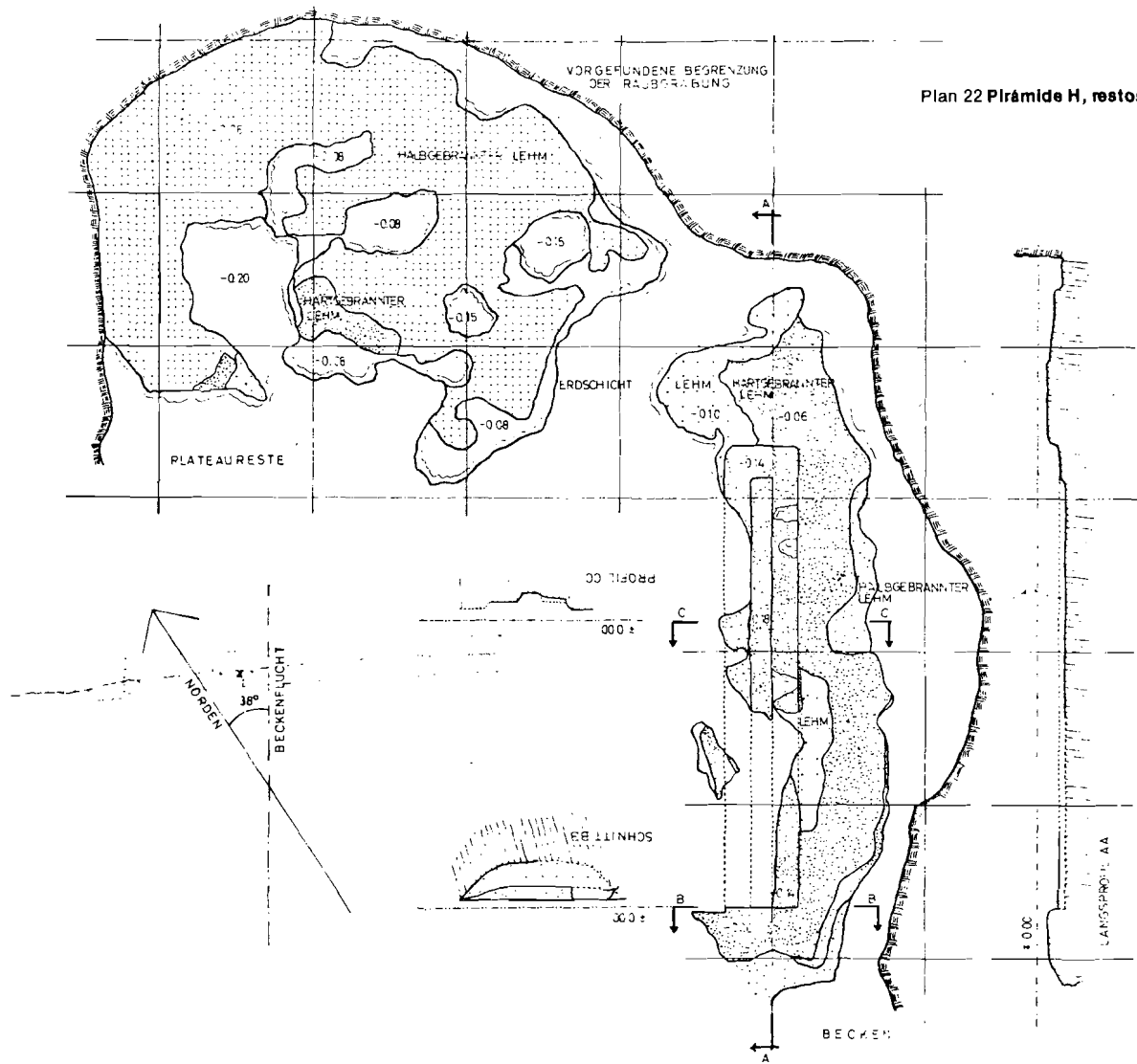

OBERFLÄCHENNEUBAU

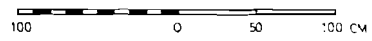

COCHASQUI - AUSGRABUNG
 RESTE EINER BECKENANLAGE AUF
 DER PYRAMIDE H
 GRUNDRISS M 1:20 3764 G.J.

Plan 23 al este de la Pirámide C, restos de un conjunto de moldes, plan y perfil.

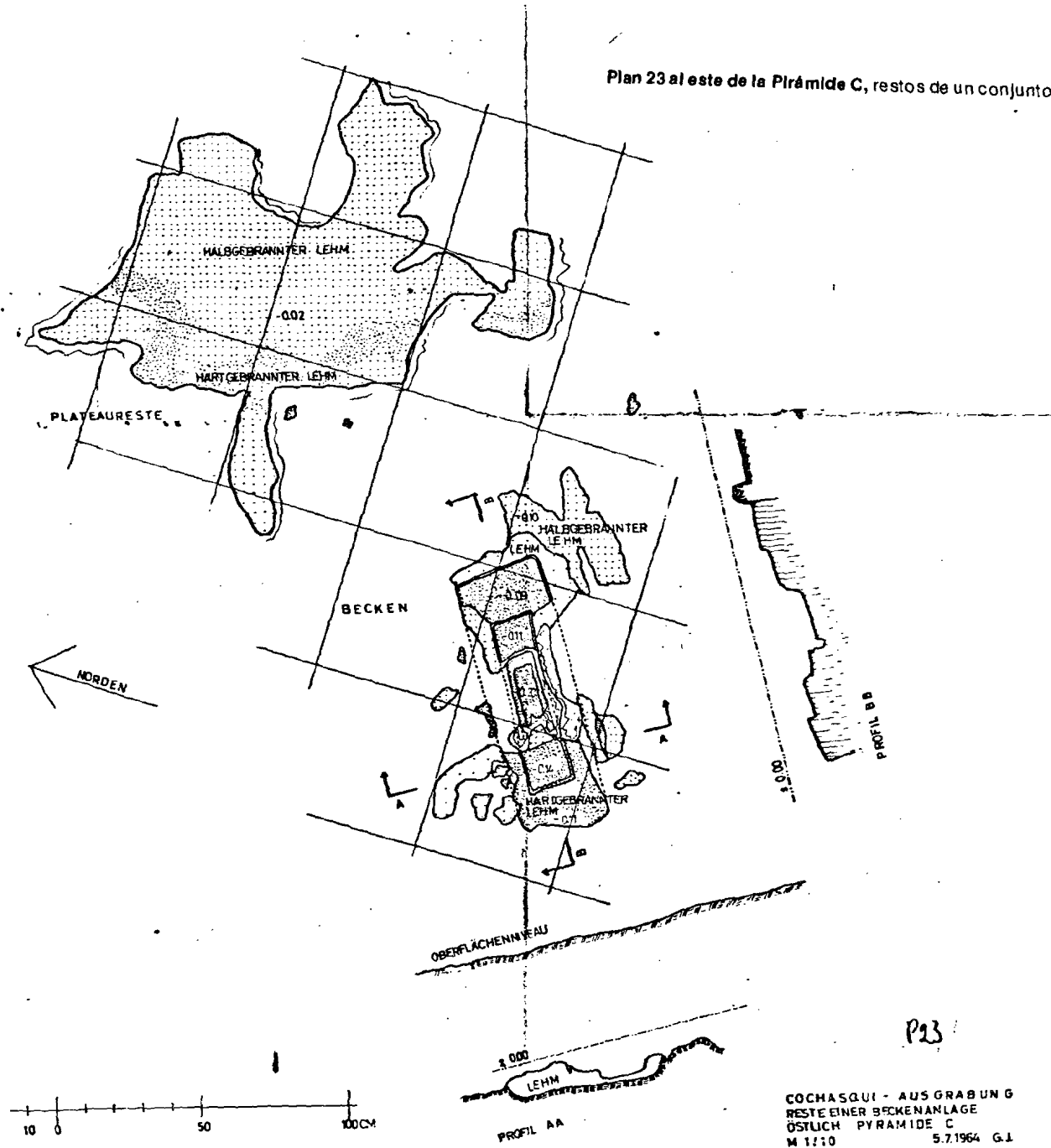

P23
COCHASQUI - AUSGRABUNG
RESTE EINER BECKENANLAGE
ÖSTLICH PYRAMIDE C
M 1:10 5.7.1964 G.1

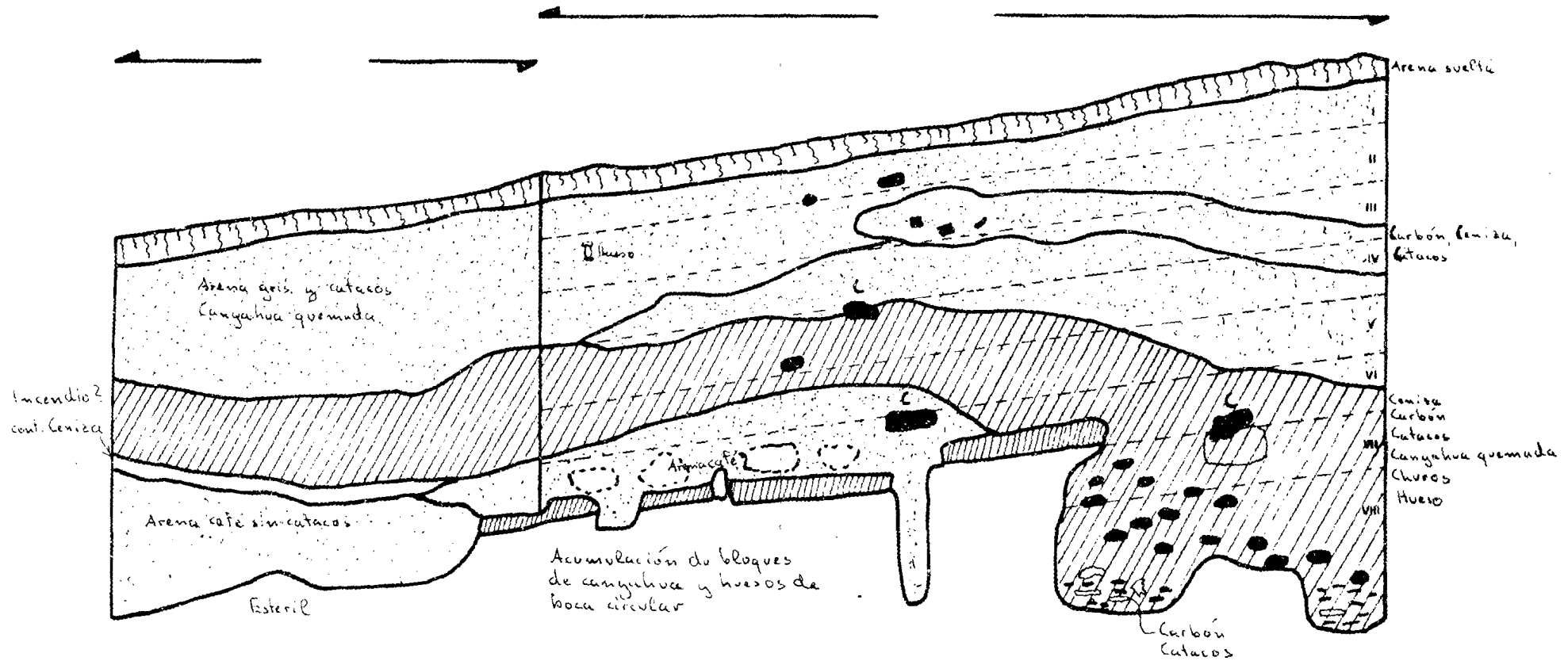

PERFIL PARED ESTE - CORTE ESTRATIGRAFICO/ARTIFICIAL

COCHASQUI - sitio: Salado Ajambi M. 1:20

Plan 24 Ajambi, perfil pared este-corte estratigráfico/artificial.

IOA

INSTITUTO OTAVALEÑO DE ANTROPOLOGIA

editorial

GALLOCAPITÁN
Otavalo-Ecuador